

X-Y-Z Stepper Motor Controller Mechanical Data and Pin Configuration

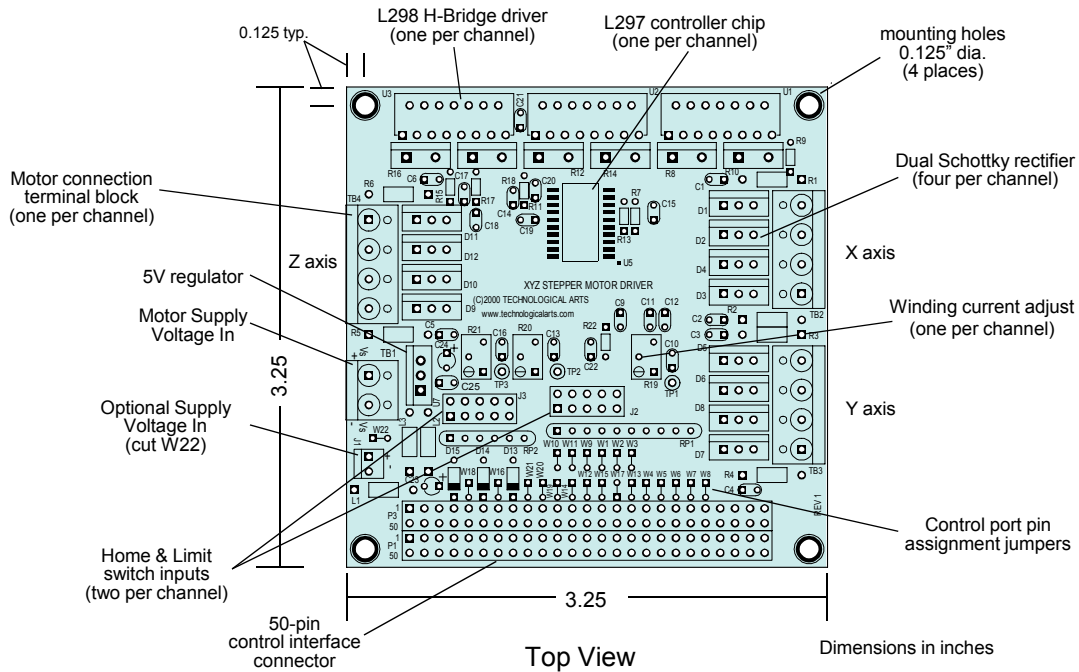

P1/P3 Pin Assignments

PIN #	SIGNAL NAME	PIN #	SIGNAL NAME
1	not used	50	GROUND
2	not used	49	GROUND
3	not used	48	not used
4	not used	47	+5V
5	not used	46	IRQ* (LIMITS)
6	not used	45	not used
7	not used	44	RESET*
8	not used	43	not used
9	not used	42	Z LIMIT
10	not used	41	Y LIMIT
11	X HOME	40	X LIMIT
12	Y HOME	39	XYZ EN
13	Z HOME	38	X CTRL
14	Y HALF	37	Y CTRL
15	Z HALF	36	Z CTRL
16	X DIR	35	X HALF
17	X STEP	34	not used
18	Y STEP	33	not used
19	Y DIR	32	not used
20	Z STEP	31	not used
21	Z DIR	30	not used
22	not used	29	not used
23	not used	28	not used
24	not used	27	not used
25	not used	26	not used

NOTE: * indicates active low

Order Code:
AD12DXXYZSM-□(□)
(fill in desired connector option)



Standard Connector Options

