

# X68C75 SLIC® E<sup>2</sup> Microperipheral

## Port Expander and E<sup>2</sup> Memory

### FEATURES

- **Highly Integrated Microcontroller Peripheral**
  - 8K x 8 E<sup>2</sup> Memory
  - 2 x 8 General Purpose Bidirectional I/O Ports
  - 16 x 8 General Purpose Registers
  - Integrated Interrupt Controller Module
  - Internal Programmable Address Decoding
- **Self Loading Integrated Code (SLIC)**
  - On-Chip BIOS and Boot Loader
  - IBM/PC Based Interface Software(XSLIC)
- **Concurrent Read During Write**
  - Dual Plane Architecture
- **Isolates Read/Write Functions Between Planes**
- **Allows Continuous Execution Of Code From One Plane While Writing In The Other Plane**
- **Multiplexed Address/Data Bus**
  - Direct Interface to Popular 68HC11 Family of Microcontrollers
- **Software Data Protection**
  - Protect Entire Array During Power-up/-down
- **Block Lock™ Data Protection**
  - Set Write Lockout in 1K Blocks
- **Toggle Bit Polling**

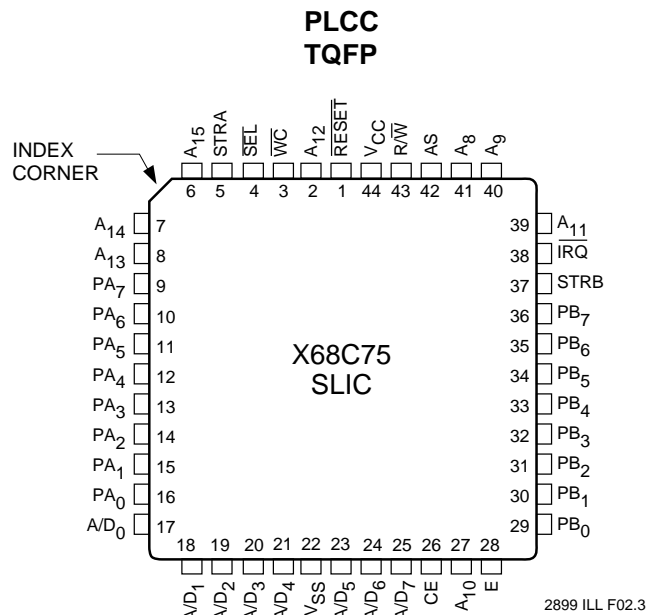
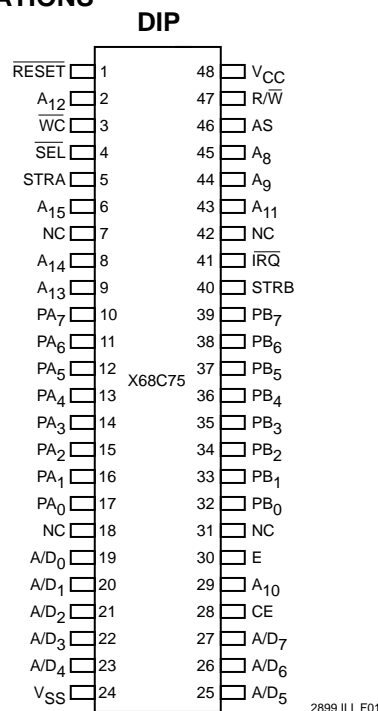
- **High Performance CMOS**
  - Fast Access Time, 120ns
  - Low Power
    - 60mA Active
    - 100µA Standby
- **PDIP, PLCC, and TQFP Packaging Available**

### DESCRIPTION

The X68C75 is a highly integrated peripheral for the 68HC11 family of microcontrollers. The device integrates 8K-bytes of 5V byte-alterable nonvolatile memory, 2 bidirectional 8-bit ports, 16 general purpose registers, programmable internal address decoding and a multiplexed address and data bus.

The 5V byte-alterable nonvolatile memory can be used as program storage, data storage, or a combination of both. The memory array is separated into two 4K-byte sections which allows read accesses to one section while a write operation is taking place in the other section. The nonvolatile memory also features Software Data Protection to protect the contents during power transitions, and an advanced Block Protect register which allows individual blocks of the memory to be configured as read-only or read/write.

### PIN CONFIGURATIONS



Concurrent Read During Write, Block Lock, and SLIC® E<sup>2</sup> are registered trademarks of Xicor, Inc.

# X68C75 SLIC® E<sup>2</sup>

Each bidirectional port consists of 8 general purpose I/O lines and 1 data strobe line. The ports also feature a configurable interrupt request output.

Access to the X68C75 is accomplished through the multiplexed address/data bus of the 68HC11 type controllers. An internal programmable address decoder maps the internal memory and register locations into the desired address space.

## ARCHITECTURAL OVERVIEW

The X68C75 incorporates the interface circuitry normally needed to decode the control signals and demultiplex the address/data bus to provide a “seamless” interface.

The control inputs on the X68C75 are configured such that it is possible to directly connect them to the proper interface signals of the 68HC11 microcontroller. The reading of data from the chip is controlled by the R/W and E clock signals.

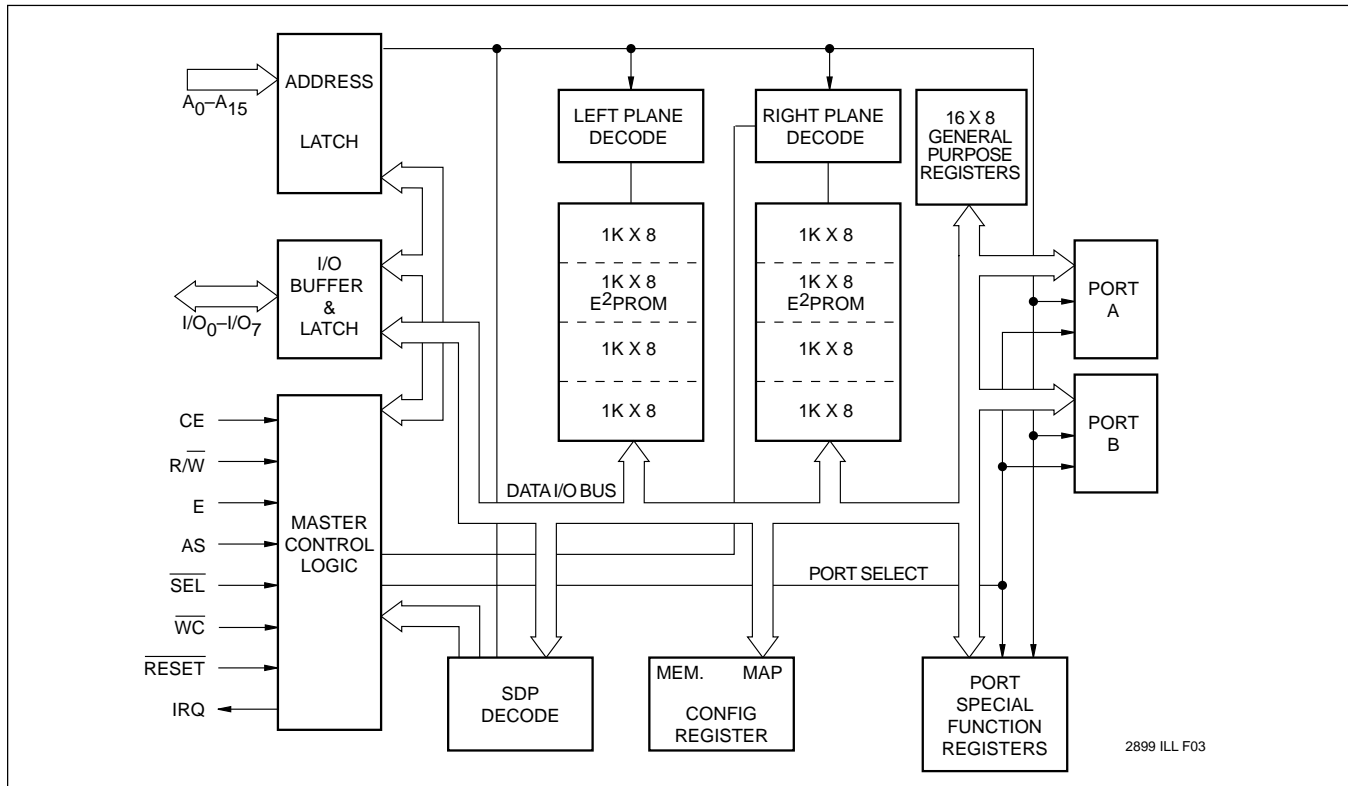
Reading and writing of the nonvolatile memory array is analogous to RAM operation. During a write operation to either the nonvolatile memory or the control registers, the falling edge of AS latches the address present on the

address bus into the X68C75, and the falling edge of E clock latches the data to be written.

The nonvolatile memory of the X68C75 is internally organized as two independent arrays of 4K-bytes with the A12 input selecting which of the two planes of memory is to be accessed. While the processor is executing code out of one plane, write operations can take place in the other plane; allowing the processor to continue execution of code out of the X68C75 during a byte or page write to the device. This feature is called Concurrent Read During Write.

The X68C75 also features an advanced implementation of the Software Data Protection scheme, called Block Protect, which allows the nonvolatile memory array to be treated as 8 independent sections of 1K-bytes. Each of these sections can be independently enabled for write operations. This allows segmentation of the memory contents into writable and non-writable sections, thereby, allowing certain sections of the device to be secured so that updates can only occur in a controlled environment. (e.g. in an automotive application, only at an authorized service center). The Block Protect configuration is stored in a nonvolatile register, ensuring that the configuration data will be maintained after the device is powered-down.

## FUNCTIONAL DIAGRAM



2899 ILL F03

## X68C75 SLIC® E<sup>2</sup>

The X68C75 write control input, serves as an external control over the completion of a previously initiated page load cycle.

The X68C75 also features the industry standard 5V E<sup>2</sup> memory characteristics such as byte or page mode write and Toggle Bit Polling.

### Read

A HIGH to LOW transition on AS latches the address; the data will be output on the AD pins when E clock and R/W are HIGH ( $t_{ACC}$ ).

### Write

A write is performed by latching the address on the falling edge of AS. The R/W signal LOW while E clock is HIGH initiates a write cycle. The valid data must be present on AD<sub>0</sub>-AD<sub>7</sub> prior to an E clock HIGH to LOW

transition. The data will be latched into the X68C75 on the falling edge of E clock.

### Page Write Operation

The X68C75 supports page mode write operations. This allows the microcontroller to write from one to thirty-two bytes of data to the X68C75. Each individual write within a page write operation must conform to the byte write timing requirements. The rising edge of E clock starts a timer delaying the internal programming cycle 100 $\mu$ s, therefore, each successive write operation must begin within 100 $\mu$ s of the last byte written. The waveform on page 19 illustrates the sequence and timing requirements.

### Toggle Bit Polling

Because the X68C75 typical write timing is less than the specified 5ms, Toggle Bit Polling has been provided to

## PIN DESCRIPTIONS

PIN NAME	I/O	DESCRIPTION
A <sub>15</sub> -A <sub>8</sub>	I	Non-multiplexed high-order Address line inputs for the upper byte of the address. The addresses are latched when AS makes a HIGH to LOW transition.
AD <sub>7</sub> -AD <sub>0</sub>	I/O	Multiplexed lower-order Address and DATA lines. The addresses are latched when AS makes a HIGH to LOW transition.
AS	I	Address Strobe input is used to latch the addresses present on the address lines A <sub>15</sub> -A <sub>8</sub> and AD <sub>7</sub> -AD <sub>0</sub> into the device. The addresses are latched when AS transitions from HIGH to LOW.
CE	I	The device select (CE) is an active HIGH input. This signal has to be asserted prior to AS HIGH to LOW transition in order to generate a valid internal device select signal. Holding this pin LOW and AS LOW will place the device in standby mode. The ports stay active at all times.
E	I	The E clock is the bus frequency clock input, and is used as a data timing reference signal. When the E clock is LOW, the addresses are latched by HIGH to LOW transition on the AS pin. The E clock HIGH cycle is used for data transfers.
$\overline{IRQ}$	O	The $\overline{IRQ}$ is an open-drain output. It can be configured to signal latching of new data into the ports, and completion of an E <sup>2</sup> memory write cycle.
PA <sub>7</sub> -PA <sub>0</sub>	I/O	The I/O lines of port A. The output driver can be configured as either CMOS or open-drain using the AWO bit in CR. The I/O direction bit (DIRA) in CR is used to select the port A I/O mode.
PB <sub>7</sub> -PB <sub>0</sub>	I/O	The I/O lines of port B. The output driver can be configured as either CMOS or open-drain using the BWO bit in CR. The I/O direction bit (DIRB) in CR is used to select the port B I/O mode.
R/W	I	The R/W signal indicates the direction of data transfers. During phase 2 (HIGH cycle) of the E clock, the R/W is HIGH for a read, and LOW for a write cycle.
RESET	I	RESET is used to initialize the internal static registers and has no effect on the E <sup>2</sup> memory operations. The default active level is LOW, but it can be reconfigured in EEM register.
$\overline{SEL}$	I	The $\overline{SEL}$ input should be LOW for the device to be selected. This input is normally tied to V <sub>SS</sub> .
STRA, STRB	I/O	The STRA controls port A and STRB controls port B. When ports are configured as inputs, a valid transition on their strobe pins will latch into their Port Data Register the data present at the port input pins. Writing to an output port Data Register generates a pulse of fixed duration on its corresponding strobe pin. The output data presented at the output pins stay valid until the next data is written to the output port data register.
$\overline{WC}$	I	$\overline{WC}$ input has to be held LOW during a write cycle. It can be permanently tied HIGH in order to disable writes to the E <sup>2</sup> memory. Taking the $\overline{WC}$ HIGH prior to $t_{BLC}$ (100 $\mu$ s; the time delay from the last write cycle to the start of internal programming cycle) will inhibit the write operation.

2899 PGM T01.1

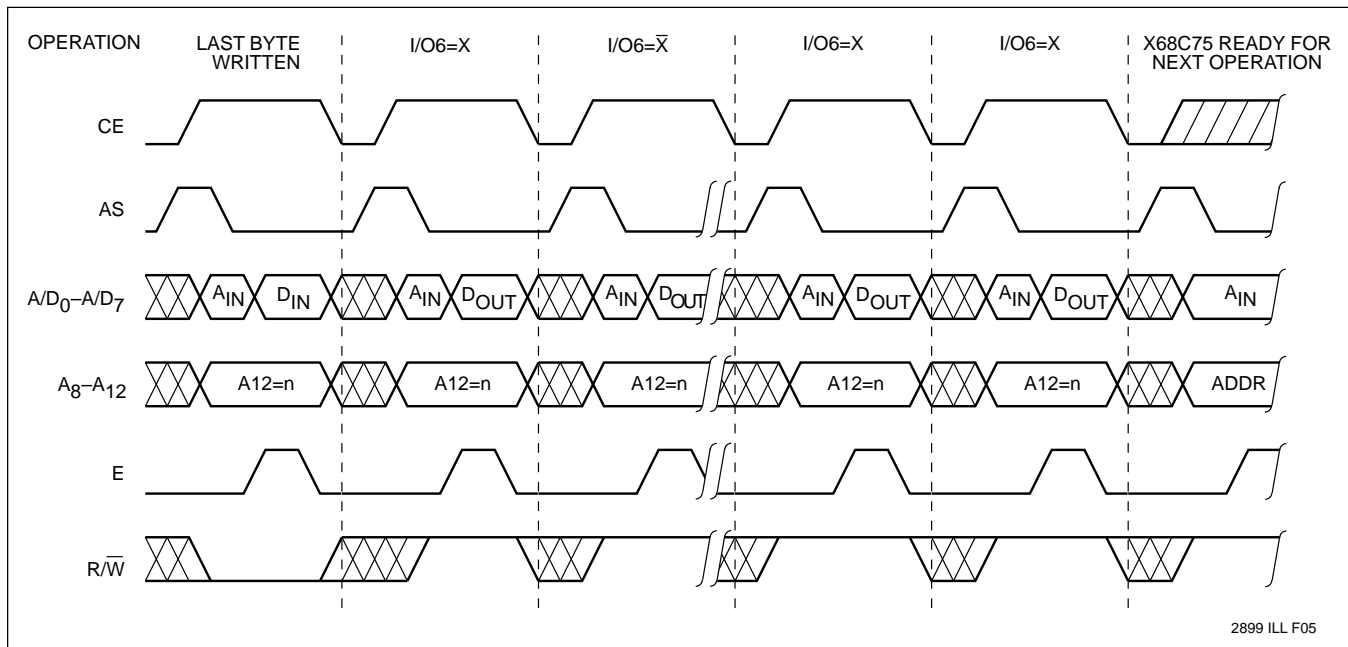
# X68C75 SLIC® E<sup>2</sup>

determine the early completion of a write cycle. During the internal programming cycle, I/O<sub>6</sub> will toggle from “1” to “0” and “0” to “1” on subsequent attempts to read from the memory plane that is being updated. When the internal cycle is complete, the toggling will cease and the device will be accessible for additional read or write operations. Due to the dual plane architecture, reads for polling must occur from the plane that was written; that is, the state of A<sub>12</sub> during a write must match the state of A<sub>12</sub> during polling.

## DATA PROTECTION

The X68C75 provides two levels of data protection through software control. There is a global software data protection feature similar to the industry standard for E<sup>2</sup>PROMs and a new Block Lock Protect write lockout protection providing a secondary level data security option.

**Figure 1. Toggle Bit Polling E Control**



## Software Data Protection

Software Data Protection (SDP) can be employed to protect the entire array against inadvertent writes during power-up/power-down operations. The X68C75 is shipped from the factory with SDP enabled. With SDP enabled, inadvertent attempts to write to the X68C75 will be blocked.

The system can still write data, but only when the write operation (page or byte) is preceded by the three-byte command sequence. All write operations, both the command sequence and any data write operations must conform to the page write timing requirements.

The SDP mode is also enabled anytime one of the nonvolatile configuration registers are modified. These include writing to EE map, SFR map, and BPR.

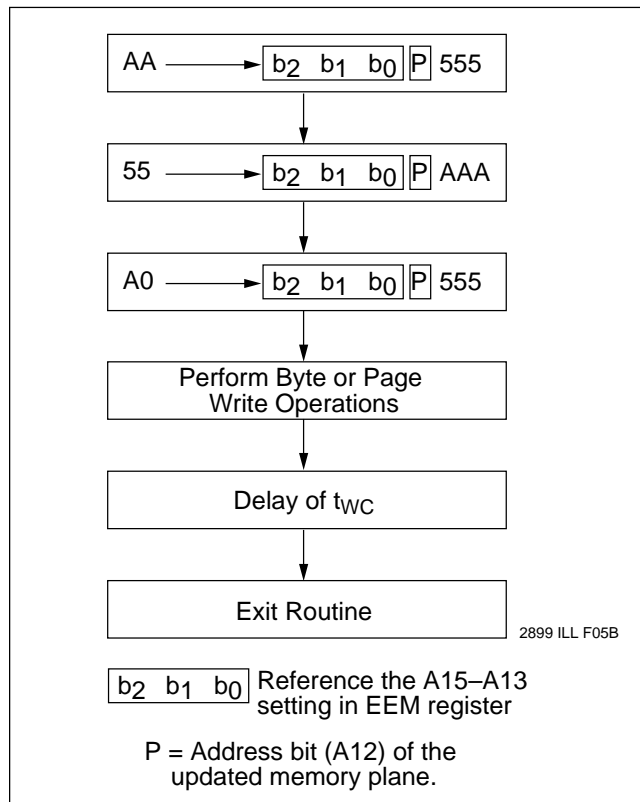
## Block Lock Protect Write Lockout

The X68C75 provides a second level of data security referred to as Block Lock Protect write lockout (or Block Protection). This is accessed through an extension of the SDP command sequence. Block Protect allows the user to lockout writes to 1K x 8 blocks of memory. Unlike SDP which prevents inadvertent writes, but still allows

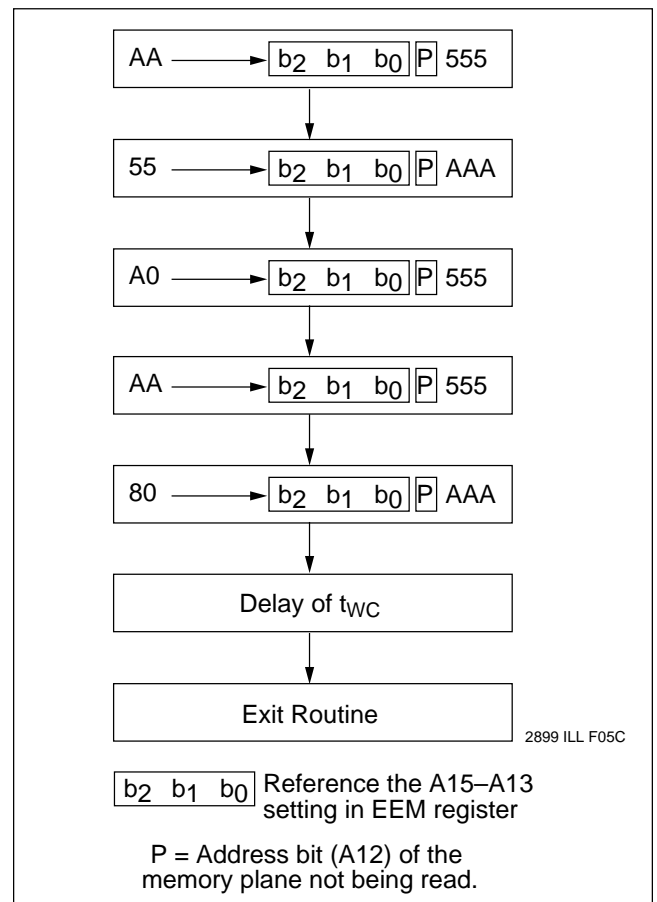
easy system access to writing the memory, Block Protect will lockout all attempts unless it is specifically disabled by issuing the deactivation sequence. This feature can be used to set a higher level of protection in a system where a portion of the memory is used to store the system kernel and protect it from the application programs residing in the other blocks.

Setting write lockout is accomplished by writing a five-byte command sequence opening access to the Block Protect Register (BPR). After the fifth byte is written, the user writes to the BPR, selecting which blocks to protect or unprotect. All write operations, both the command sequence and writing the data to the BPR, must conform to the page write timing requirements. It should be noted that accessing the BPR automatically sets the upper level SDP. If for some reason the user does not want SDP enabled, they may reset it using the normal reset command sequence. This will *not* affect the state of the BPR and any 1K x 8 blocks that were set to the write lockout state will remain in the write lockout state.

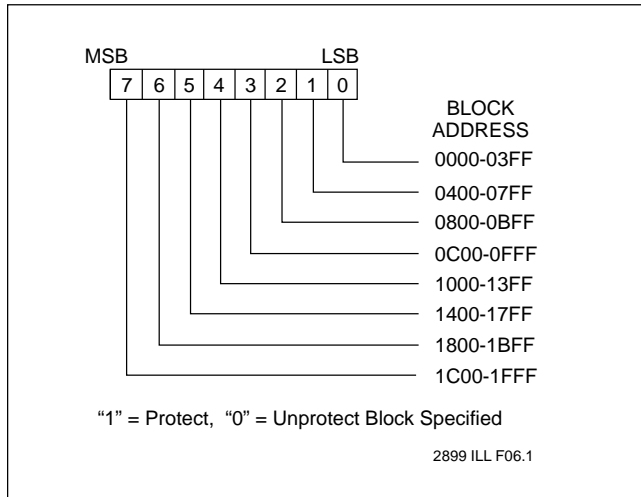
**Figure 2. Writing with SDP Enabled**



**Figure 3. Sequence to Deactivate Software Data Protection**

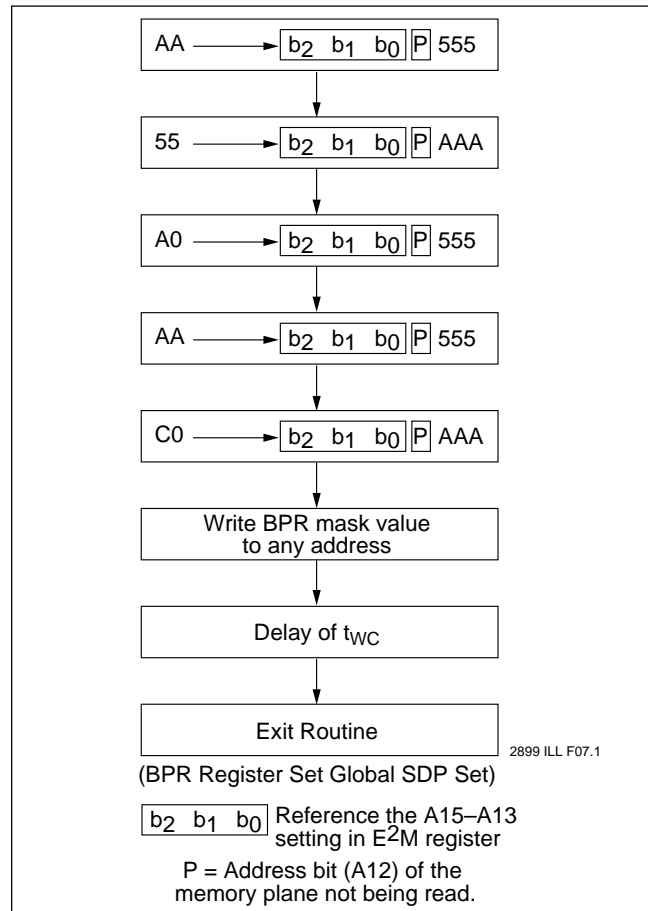


**Figure 4. Block Protect Register Format**

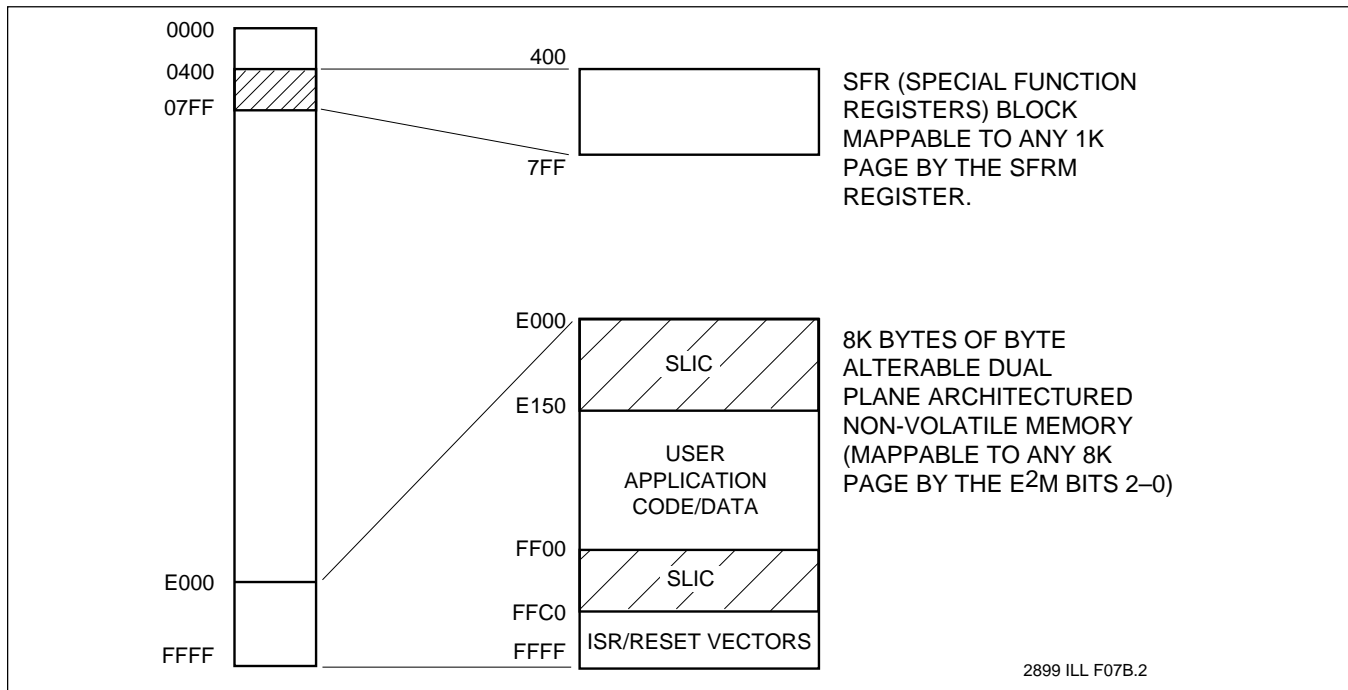


The BPR format and block map are illustrated above. The command sequence is illustrated to the right.

**Figure 5. Setting BPR Command Sequence**

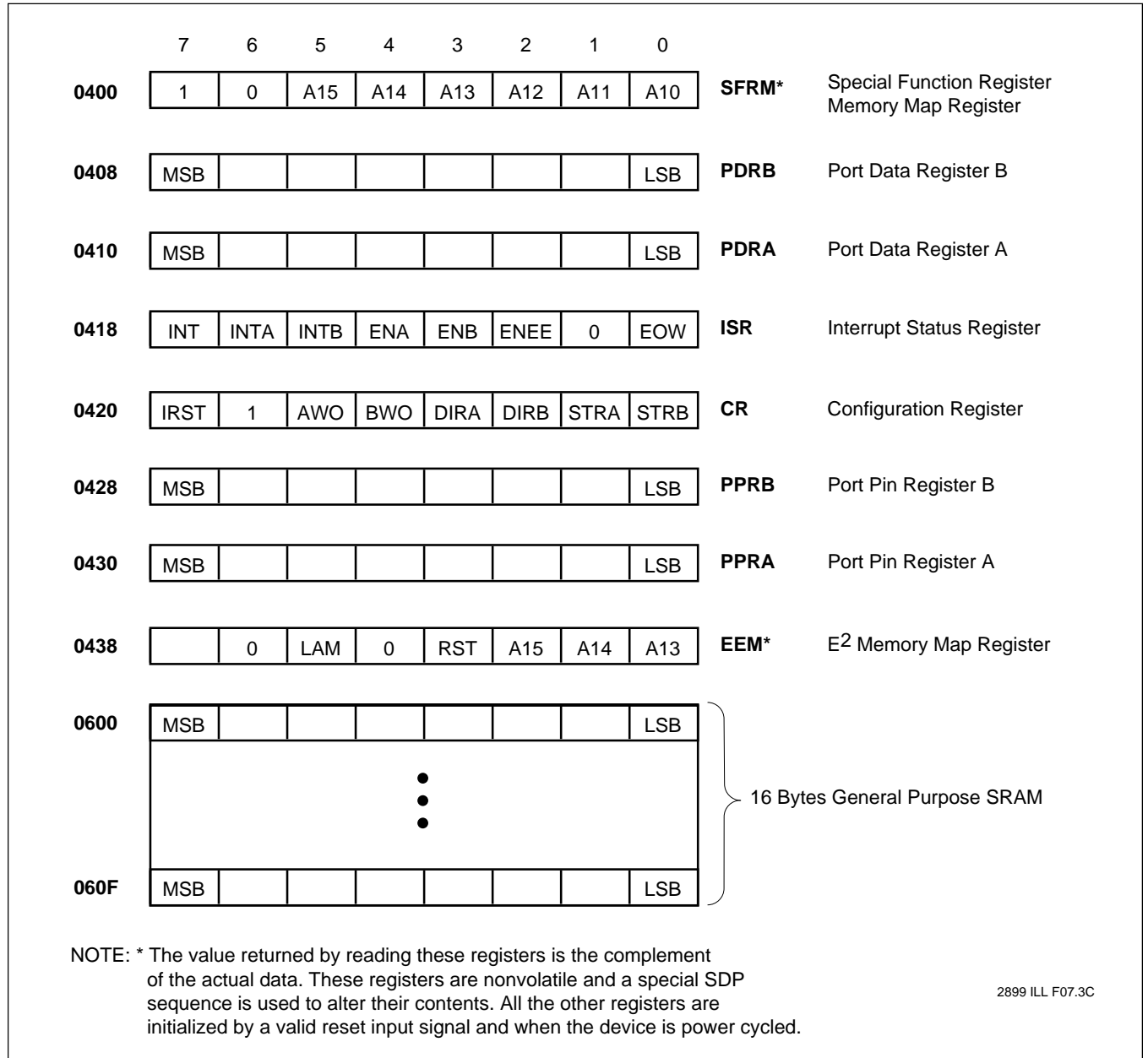


**Figure 6. Microcontroller Map**



# X68C75 SLIC® E<sup>2</sup>

**Figure 7. On-Chip Registers**



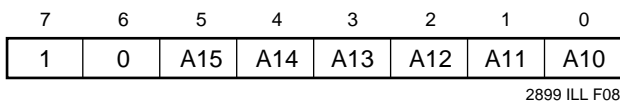
2899 ILL F07.3C

# X68C75 SLIC® E<sup>2</sup>

## Programmable Address Decoding

The X68C75 features an internal programmable address decoder which allows the nonvolatile memory array and the internal registers to be mapped in various locations of the 64K-byte memory map. The register set is mappable into a 1K-byte block, while the nonvolatile memory array is mappable into an 8K-byte block. The mapping is controlled by two nonvolatile configuration registers, the SFR Map Register and the E<sup>2</sup> Memory Map Register. Their bits are mapped as follows:

### SFR Map Register (SFRM) Default = 81



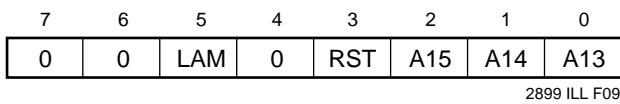
### A15-A10

A15-A10 are upper address bits for the 1K-byte page where the SFR memory is mapped.

### BITS 7:6

Setting these two bits to any combination other than “10” will interfere with device proper operation.

### E<sup>2</sup> Memory Map Register (EEM) Default = 07



### A15-A13

Modifying these three bits changes the location of the program memory within the address map. The A15-A13 correspond to the upper three address bits of the 8K-byte page where program memory will be mapped.

### RST

The RST bit controls the polarity of the RESET input pin.

- “0” = RESET is Active LOW
- “1” = RESET is Active HIGH

### LAM

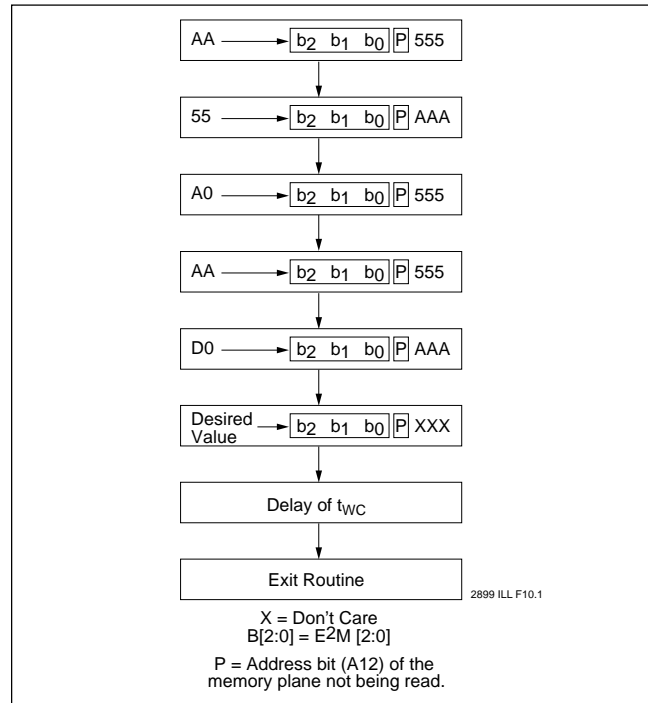
Port B can be configured as either a general purpose I/O port (normal I/O mode), or latched address mode (LAM). The LAM option programs port B to output the demultiplexed low order byte of the address latched into the X68C75 by AS. The LAM bit selects between these two modes.

- “0” = Port B is an I/O Port
- “1” = Port B outputs low address byte (A7-A0)

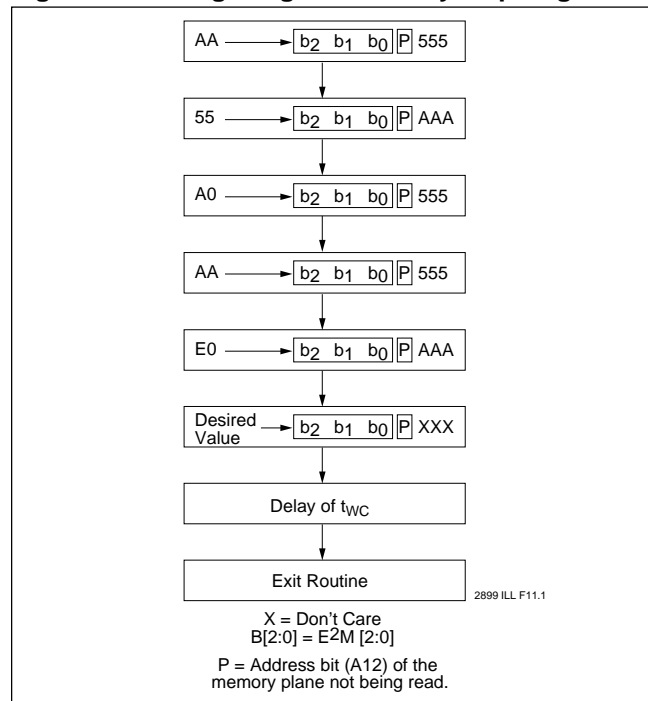
## Setting the Mapping Registers

The mapping registers are written using a modified version of the Software Data Protection sequence. All timings must adhere to the normal Software Data Protection sequence.

**Figure 8. Setting the SFR Map Register**



**Figure 9. Setting Program Memory Map Register**



# X68C75 SLIC® E<sup>2</sup>

The complemented contents of the SFR map register and the E<sup>2</sup> memory map register can be read by the microcontroller at their corresponding SFR addresses. The physical memory location of these registers can be derived by adding the following offset to the SFR base address:

SFR Map Register	00H
E <sup>2</sup> Memory Map Register	38H

If the regions specified in the map registers overlap, only the SFR will be accessible.

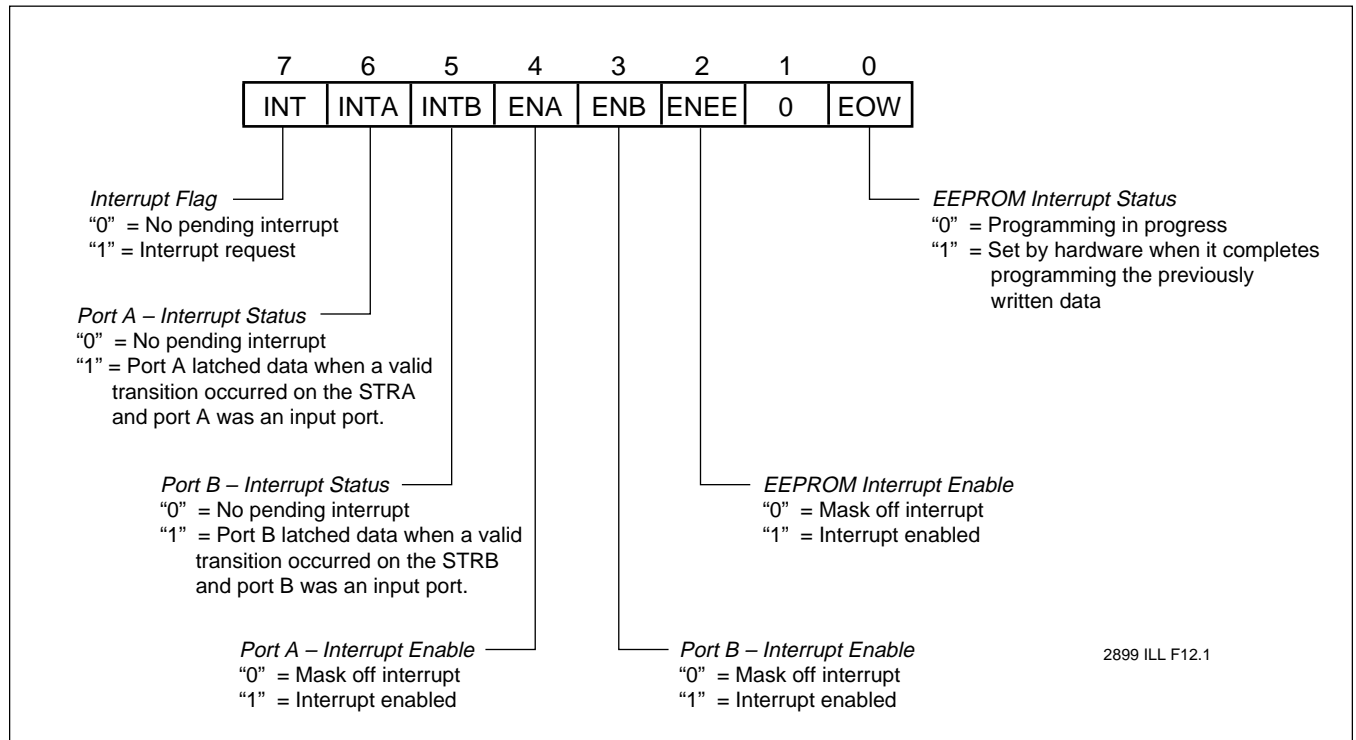
### Interrupt Status Register (ISR)

The Interrupt Status Register is a volatile register used to configure the interrupt condition for the I/O ports as well as to determine the interrupt status of the ports. The X68C75 ports can generate an interrupt to the microcontroller upon the proper transition (as specified in the configuration register) on either STRA or STRB pins when the corresponding I/O port is configured as an input.

The INT flag is set when any of input strobes are toggled provided that their corresponding interrupt enable bits (ENA, ENB) are set. The INT flag is cleared when latched data is read (PDR ) or pending interrupt status flag (INTA, INTB) in ISR is forced to "0" by the interrupt service routine. Interrupt service routine should examine the interrupt status flags (INTA, INTB) and identify the source of pending interrupt.

The E<sup>2</sup> memory interrupt status flag (EOW) is another means to detect the early completion of a write cycle. When ENEE is enabled, the hardware will set the EOW flag, and interrupt the microcontroller at the end of an internal programming cycle. Toggle Bit Polling can be replaced by the EOW hardware interrupt, which reduces the software overhead. The EOW flag should be cleared by software. The interrupt status register bits are mapped as follows.

**Figure 10. Interrupt Status Register**



## Configuration Register (CR)

The Configuration Register is a volatile register used to configure the operation of the I/O ports. The configuration register allows the microcontroller to designate whether each of the two ports is an input or output, what type of output drive is to be used, and specifies the polarity of the two strobe lines, STRA and STRB. The bit map of configuration register is shown below.

The IRST bit in the configuration register controls the method used to clear the port interrupt request flags (INTA, INTB). The interrupts are reset by either reading the interrupt source or writing to the interrupt status register. The interrupt must be disabled prior to changing strobe polarity bits (STPA, STPB), or port direction bits (DIRA, DIRB) in CR. Otherwise, any attempt to modify the status of these bits may cause an interrupt to occur.

## Port Data Registers (PDR)

The PDRA/PDRB are byte-wide latches which hold port data. When a port is configured as an output, the outputs of its PDR latch are connected to the port pins. Writing to PDR generates a pulse on the port strobe pin and latches the data. If a port is configured as an input, the inputs of its PDR latch are connected to the port pins. External data is latched into PDR on the positive edge of its clock. The port strobe input and strobe polarity bit (STPA, STPB) are XORed to generate the PDR input clock.

## Port Pin Registers (PPR)

The read-only Port Pin Registers are used for reading the current status of the external I/O port pins. Accessing the PPR causes the values on the port pins to be placed on the data bus.

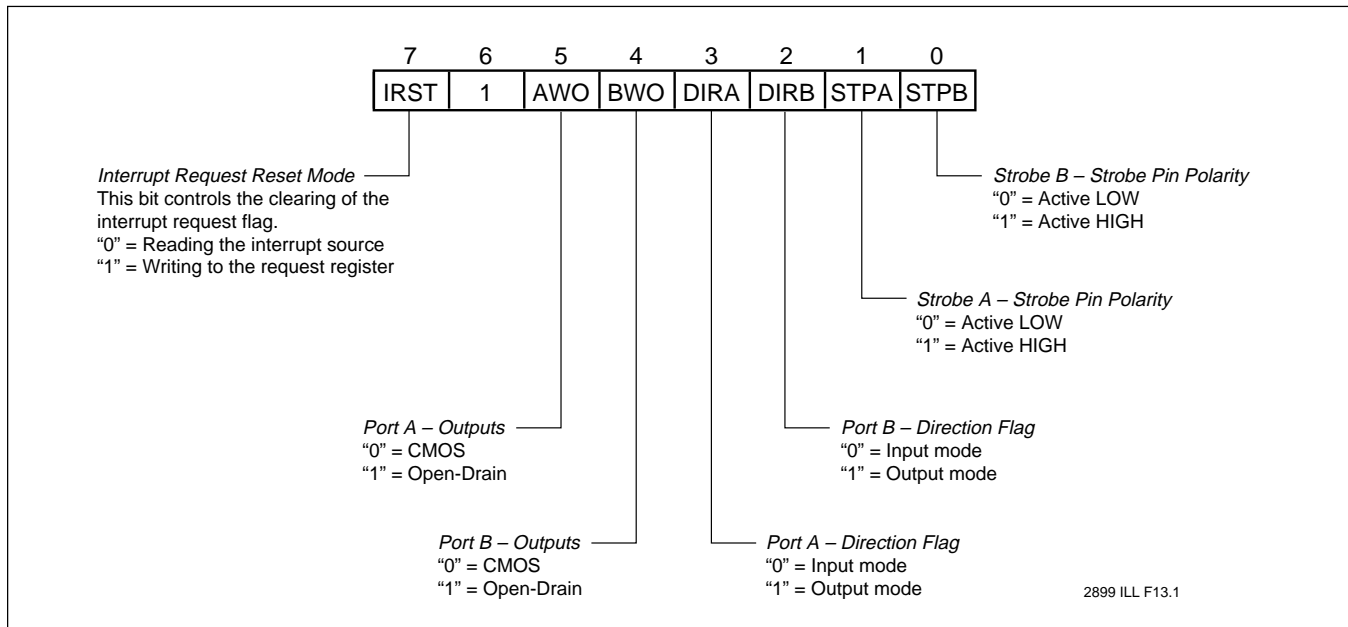
The port direction control bits in configuration register set the direction for the entire port and no control mechanism is provided to program the direction of individual pins. However, the ports have a flexible architecture which allows operating I/O ports in bidirectional mode using the PPR read feature.

A port can be operated in input/output mode by configuring it as an open-drain output port. The port wire-OR bit (AWO, or BWO) and its port data direction bit (DIRA, or DIRB) in CR, should be set to "1". The PDR bits which correspond to the port pins assigned as inputs should be programmed to "1". For monitoring the status of the input pins, the PPR can be read. In this application the port strobe pin and the PDR latch are in output mode. In open-drain mode, there are weak internal pull-ups on the port pins, however external pull-ups must be used for proper switching of the I/O lines.

## Static RAM Block

There are 16 bytes of volatile static RAM registers mapped to the SFR region. They reside in the 200H-20FH area offset from the SFR base address. Accessing these registers has to be done through external RAM operations for both writes and reads.

**Figure 11. Configuration Register**





## PRINCIPLES OF OPERATION

### I/O Ports Operation

The expansion ports are accessible to the software using their assigned memory mapped addresses. Each port occupies two addresses in the SFR plane, the Port Data Register and Port Pin Register. These registers and their location in the 1K-byte register memory space is shown on page 7.

The ports can be configured as either inputs or outputs, the DIRA and DIRB bits in the configuration register are used to select between the modes. The input signal on the strobe pin, when the corresponding port is configured as an input, is fed to the clock input of the port latch. These are transparent latches and the trailing edge of the strobe pulse is used to latch the data present on the input pins. The strobe signal polarity is configurable using the STPA and STPB bits in the configuration register.

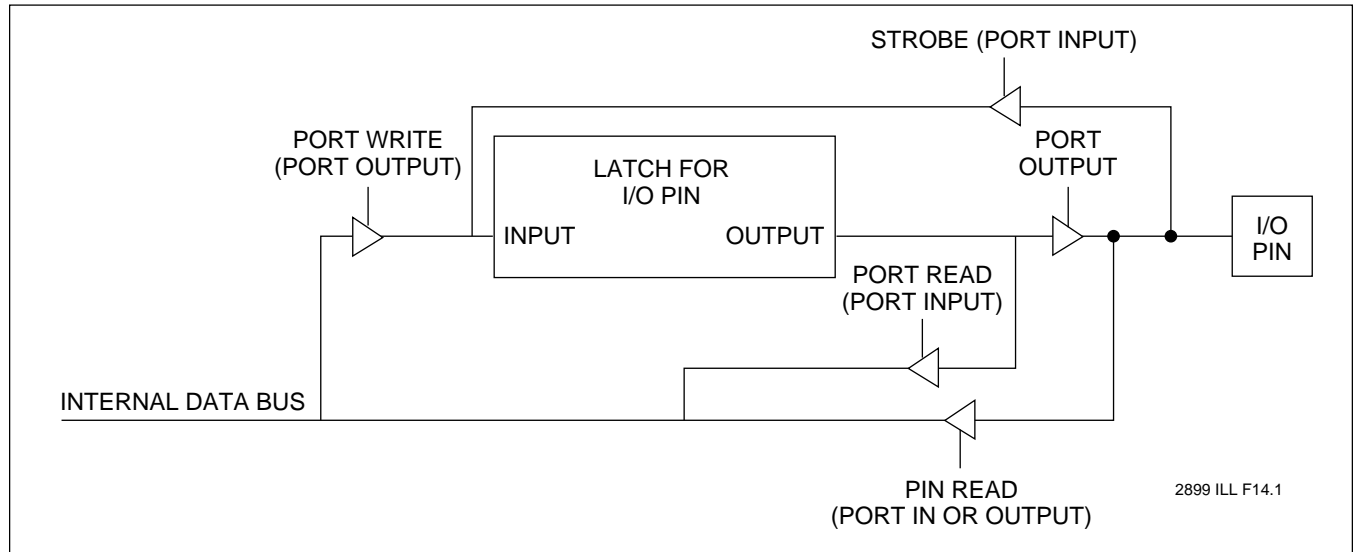
Writing to the port data register of an output port will generate a pulse of fixed duration on its strobe pin. The data also simultaneously arrives at the port output pins.

The latched data stays there until new data is written to the port data register. The strobe pulse shape is controlled by the state of the STPA and STPB bits in configuration register. A "1" forces the valid transition on the corresponding strobe pin as active HIGH (  ), and a "0" sets it to active LOW (  ).

When an external strobe signal is applied to an input port, the latching of input data is followed by the setting of the interrupt flags. The INTA and INTB interrupt flags are used by ports A and B respectively, and are set along with the INT interrupt flag at the end of strobe pulse input. External interrupt ( $\overline{IRQ}$ ) is generated if the interrupt enable flags (ENA, and ENB) are set by the software. The former enables the port A interrupt and the latter the port B interrupt.

The port output drivers can be either CMOS or open-drain. The wire-OR bits (AWO, BWO) in the configuration register are used to make the selection. When the bits are "0" the CMOS drivers are enabled. Setting these bits will enable the open-drain output drivers. Small pull-up resistors should be used on the pins of open-drain outputs.

**Figure 12. Block Diagram of the I/O Ports**



## IRQ

The  $\overline{\text{IRQ}}$  pin is an active LOW open-drain output. In embedded systems applications, this signal is connected to the microcontroller interrupt input pin through either a direct connection or via an interrupt controller.

Table 1 depicts the three sources of interrupts and their associated flags. Under normal conditions, the INT and port interrupt flags are set, if the port which is configured as an input has its strobe line toggled. If the port interrupt enable flag is set, or gets set while the INT flag is set, then the  $\overline{\text{IRQ}}$  signal is asserted. The  $\overline{\text{IRQ}}$  stays valid as long as the interrupt flags are not cleared by the software or the hardware.

Another interrupt source is the End Of Write flag (EOW) which is set by the hardware at the end of every internal programming cycle. The interrupt from this source is controlled by the ENEE bit in ISR. If ENEE is enabled, then EOW can generate an external interrupt. The interrupt is cleared by setting EOW to “0”.

**Table 1. X68C75 Interrupt Sources**

Interrupt Source	Interrupt Enable	Status Flag	INT Flag
PORT A	ENA	INTA	“1”
PORT B	ENB	INTB	“1”
EOW	ENEE	EOW	—

2899 PGM T02.1

## PORTS A & B INTERRUPTS

The X68C75 features two 8-bit I/O ports which are equipped with a configurable interrupt module. The interrupts are used to signal the reception of new data at an input port data latch. When a port is configured as an output, it can no longer generate any interrupts.

The input port interrupt mechanism is controlled by the external strobe pins (STRA, STRB). Detecting a valid transition on the pins will set the interrupt flags and latch in the input data. The external interrupts from the ports can be masked off using interrupt enable bits(ENA and ENB) in ISR.

Once an external interrupt is asserted, clearing the interrupt flags will cause the  $\overline{\text{IRQ}}$  signal to return to its idle state. There are two ways of resetting the interrupt flags. The selection is made using the IRST bit in the configuration register. If IRST is set, then the interrupt flags are cleared by writing “0” to the bit positions corresponding to the interrupt flags (INTA, INTB) in ISR. When the IRST bit is cleared, reading the PDR automatically clears the interrupt flags.

## SOFTWARE CONTROLLED PORT OPERATIONS

The individual clock signals, that control the PDR input latches and load the external data present on the port pins, are generated by XORing the strobe polarity bit and the strobe input of the port. The strobe polarity bits (STPA, STPB) in CR can be used to program the active edge of the strobe inputs. However, if the external strobe input is permanently tied to  $V_{SS}$  or  $V_{CC}$ , then the strobe polarity bit controls the PDR input latch clock signal.

When a port strobe and its polarity bit have identical logic levels, the corresponding PDR latch is active and any change in the port inputs will show up at the PDR latch outputs. Holding the strobe input at current levels and changing the strobe polarity bit value will generate a positive transition on the PDR clock signal, causing the latch outputs to reflect the previous logic state of the port pins. The clock transition sets the interrupt flags, and if the interrupts have been enabled, then an external interrupt signal will be asserted.

This feature allows the port input operation by permanently tying the STRx inputs to  $V_{CC}$  or  $V_{SS}$ , and using the STPx bits in CR to control PDR latches. Another advantage of this feature are software generated interrupts. Since the clocking of the PDR latch causes the corresponding port INTx flags to be set, by enabling the interrupts the microcontroller is forced to execute the interrupt service routine responsible to service the newly latched data.

## END OF WRITE (EOW) INTERRUPT

The internal programming cycle requires several milliseconds for either a single byte write or a page write. The updated memory plane is inaccessible while the programming is in progress. However, the opposite plane is still available for program fetch and data read operations.

The X68C75 has two means of signaling end of an internal programming cycle. In the Toggle Bit Polling technique, the last written byte is successively read. Bit 6 of read data toggles while the programming cycle is still in progress. The software has to continually monitor device responses and determine if it can again access the plane.

In the other method, at the end of an internal programming cycle, the hardware sets the EOW flag. The software can either poll this flag or enable the interrupts by setting the ENEE bit in ISR. Effective use of EOW is made by clearing it prior to initiating a write operation. If

## X68C75 SLIC® E<sup>2</sup>

the interrupt is enabled, an external interrupt will be asserted at the completion of the internal write cycle. The interrupt is cleared by setting EOW to “0”.

### USING A PORT IN BIDIRECTIONAL MODE

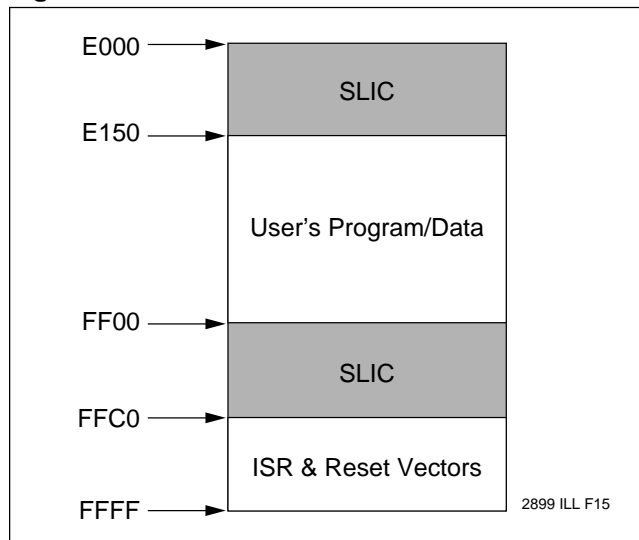
In order to use a port in bidirectional mode, it has to be configured as an open drain output port. Small pull-up resistors are required on all port output pins. Bit positions in the port data register corresponding to port inputs should contain “1”. The inputs are then read by accessing PPR. Data is not latched into the device, so the inputs must stay valid throughout the read cycle. The port strobe pin is configured as an output and cannot be used as port latch clock input.

### SLIC FUNCTIONS (68HC11 Specific SLIC)

The resident SLIC E<sup>2</sup> has designated memory spaces allocated for its use. The user’s application code should avoid using these areas as part of its code segment, otherwise it will overwrite the SLIC E<sup>2</sup>. Version 3.0 of the X68C75 SLIC E<sup>2</sup> occupies 192 bytes in the upper memory bank, FF00-FFC0H, and 336 bytes in the lower bank’s address range E000-E14FH. Prior to downloading code, assemble and link the source files using the above address information. Use memory space taken up by the SLIC E<sup>2</sup> as a run-time data storage, if there is no further need to modify the X68C75 SLIC E<sup>2</sup> content.

The current version of the SLIC E<sup>2</sup> configures the 68HC11 serial port to the variable baud rate mode. It sets a timer prescaler value for a system clock rate of 8MHz. For other clock rates, the end user must recalculate timer 1 reload value for 9600 baud rate and write it into the

**Figure 13.**



X68C75 location E024H. The XSLIC software, a PC based communication driver, automates changing of the default parameters when using its SETUP option menu. The boot-firmware (SLIC) residing on the X68C75 contains a lookup table which can be accessed from the subroutine (EXEC\_FUNC), located at location E120H. Two bytes are used per table entry. The EXEC\_FUNC input requirements are as follows:

B = Contains a function number from the following function table.

The table entry at location (E14E-E14FH) is reserved for user’s application code. This function will be executed on power-up if the SLIC receives any characters other than those for the RESET (ASCII ‘R’), or ID (ASCII ‘X’) commands. This table entry can be changed to point to other code responsible for power-up initialization. This method is preferred to changing the reset vector, since the SLIC code can still be invoked upon power-up.

Other functions available through the EXEC\_FUNC calls are as follows:

**Table 2.**

FUNCTION NO.	DESCRIPTION
0 - PROC_PROG	Download and program a page
1 - PROC_BPR	Program BPR
2 - RESET	Start execution from location E000H
3 - PROC_VER	Download and verify a page
4 - DUMMY	Command not recognized
5 - INIT_UART	Initialize UART parameters to default
6 - PROG_PG	Program a page
7 - SEND_CHAR	Send a character to the UART
8 - GET_CHAR	Read a character from the RAM receive buffer (40H-5FH)
9 - SDP_HI_PLANE	Generate SDP off sequence for upper plane
10- SDP_LO_PLANE	Generate SDP off sequence for lower plane
11- USER_CODE	Execute user’s code

2899 PGM T03.2

For detailed information about the listed functions, including their input requirements, refer to the SLIC software specification document.

# X68C75 SLIC® E<sup>2</sup>

## APPLICATION EXAMPLES

This section gives examples of most widely used embedded systems architectures using the X68C75 and 68HC11 microcontroller. However, keep in mind that other microcontrollers are also supported by the X68C75 and/or other SLIC devices that Xicor manufactures.

### Example 1

In this system, the X68C75 is the only parallel device residing on the multiplexed address and data bus. There may be other peripherals on the system board which are controlled by the ports on the X68C75. This configuration maps the EEM to a memory address in the range of E000-FFFFH. The SFRM can be mapped to any of the 64 x 1K pages within the memory space.

### Example 2

Applications requiring more than 8K bytes of program memory can be implemented using the basic system architecture depicted in example 1 along with an additional memory device such as the X28C256. Since this device requires non-multiplexed address/data buses, the X68C75 LAM feature is used to output the low order address byte. The SFRM can be mapped to any 64x1K page, but the X28C256 should be mapped to the low memory address space and out of the E<sup>2</sup>M address range (E000-FFFFH). This technique may also be used for other external byte wide memories such as SRAMs or EPROMs.

Figure 14. Example 1

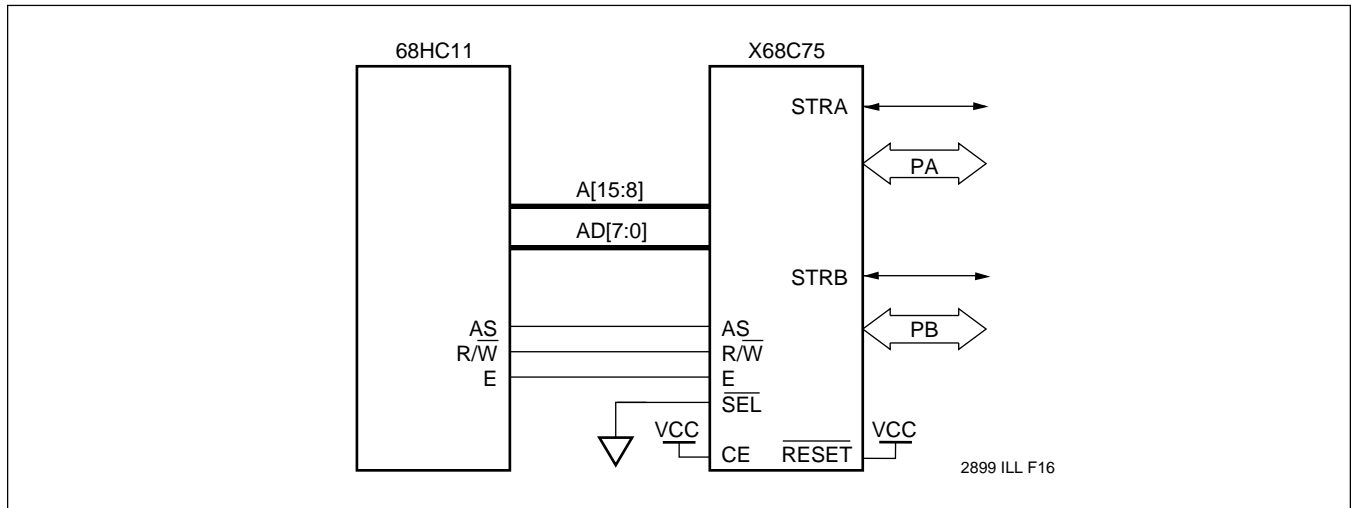
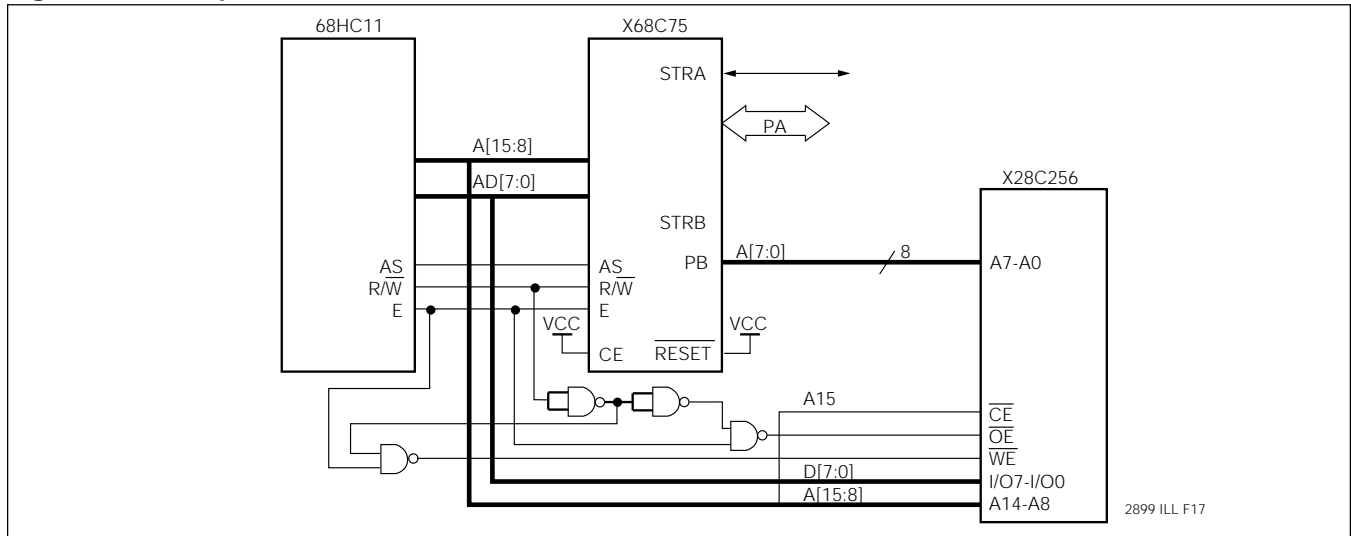


Figure 15. Example 2





# X68C75 SLIC® E<sup>2</sup>

## ABSOLUTE MAXIMUM RATINGS\*

Temperature under Bias .....	-65°C to +135°C
Storage Temperature .....	-65°C to +150°C
Voltage on any Pin with Respect to V <sub>SS</sub> .....	-1V to +7V
D.C. Output Current .....	5mA
Lead Temperature (Soldering, 10 seconds) .....	300°C

## \*COMMENT

Stresses above those listed under “Absolute Maximum Ratings” may cause permanent damage to the device. This is a stress rating only and the functional operation of the device at these or any other conditions above those indicated in the operational sections of this specification is not implied. Exposure to absolute maximum rating conditions for extended periods may affect device reliability.

## RECOMMENDED OPERATING CONDITIONS

Temperature	Min.	Max.
Commercial	0°C	+70°C
Industrial	-40°C	+85°C
Military	-55°C	+125°C

2899 PGM T04.1

Supply Voltage	Limits
X68C75	5V ±10%

2899 PGM T05.1

## D.C. OPERATING CHARACTERISTICS (Over recommended operating conditions unless otherwise specified.)

Symbol	Parameter	Limits		Units	Test Conditions
		Min.	Max.		
I <sub>CC</sub>	V <sub>CC</sub> Current (Active)		60	mA	CE = V <sub>IH</sub> , All I/O's = Open, Other Inputs = V <sub>CC</sub>
I <sub>SB1</sub> (CMOS)	V <sub>CC</sub> Current (Standby)		100	μA	CE = V <sub>IL</sub> , All I/O's = Open, Other Inputs = V <sub>CC</sub> -0.3V, AS = V <sub>IL</sub>
I <sub>SB2</sub> (TTL)	V <sub>CC</sub> Current (Standby)		2	mA	CE = V <sub>IL</sub> , All I/O's = Open, Other Inputs = V <sub>IH</sub> , AS = V <sub>IL</sub>
I <sub>LI</sub>	Input Leakage Current		10	μA	V <sub>IN</sub> = V <sub>SS</sub> to V <sub>CC</sub>
I <sub>LO</sub>	Output Leakage Current		10	μA	V <sub>OUT</sub> = V <sub>SS</sub> to V <sub>CC</sub> , E = V <sub>IL</sub>
V <sub>IL</sub> (3)	Input LOW Voltage	-1	0.8	V	
V <sub>IH</sub> (3)	Input HIGH Voltage	2	V <sub>CC</sub> + 0.5	V	
V <sub>OL</sub>	Output LOW Voltage		0.4	V	I <sub>OL</sub> = 2.1mA, Ports (A,B) I <sub>OL</sub> = 20mA
V <sub>OH</sub>	Output HIGH Voltage	2.4		V	I <sub>OH</sub> = -400μA

2899 PGM T06.1

## CAPACITANCE T<sub>A</sub> = +25°C, f = 1MHz, V<sub>CC</sub> = 5V

Symbol	Test	Max.	Units	Conditions
C <sub>I/O</sub> (4)	Input/Output Capacitance	10	pF	V <sub>I/O</sub> = 0V
C <sub>IN</sub> (4)	Input Capacitance	6	pF	V <sub>IN</sub> = 0V

2899 PGM T07

## POWER-UP TIMING

Symbol	Parameter	Max.	Units
t <sub>PUR</sub> (4)	Power-Up to Read	1	ms
t <sub>PURW</sub> (4)	Power-Up to Write	5	ms

2899 PGM T08

**Notes:** (3) V<sub>IL</sub> min. and V<sub>IH</sub> max. are for reference only and are not tested.  
(4) This parameter is periodically sampled and not 100% tested.

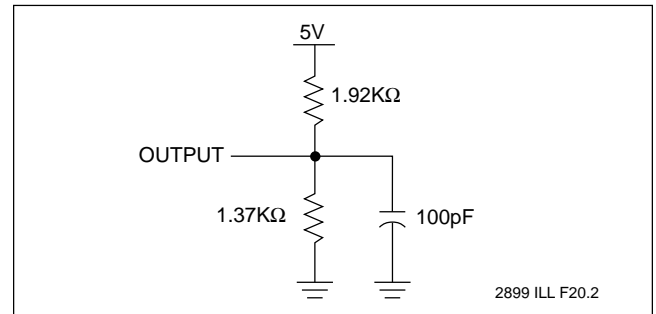
# X68C75 SLIC® E<sup>2</sup>

## A.C. CONDITIONS OF TEST

Input Pulse Levels	0V to 3V
Input Rise and Fall Times	10ns
Input and Output Timing Levels	1.5V

2899 PGM T09.1

## EQUIVALENT A.C. TEST CIRCUIT



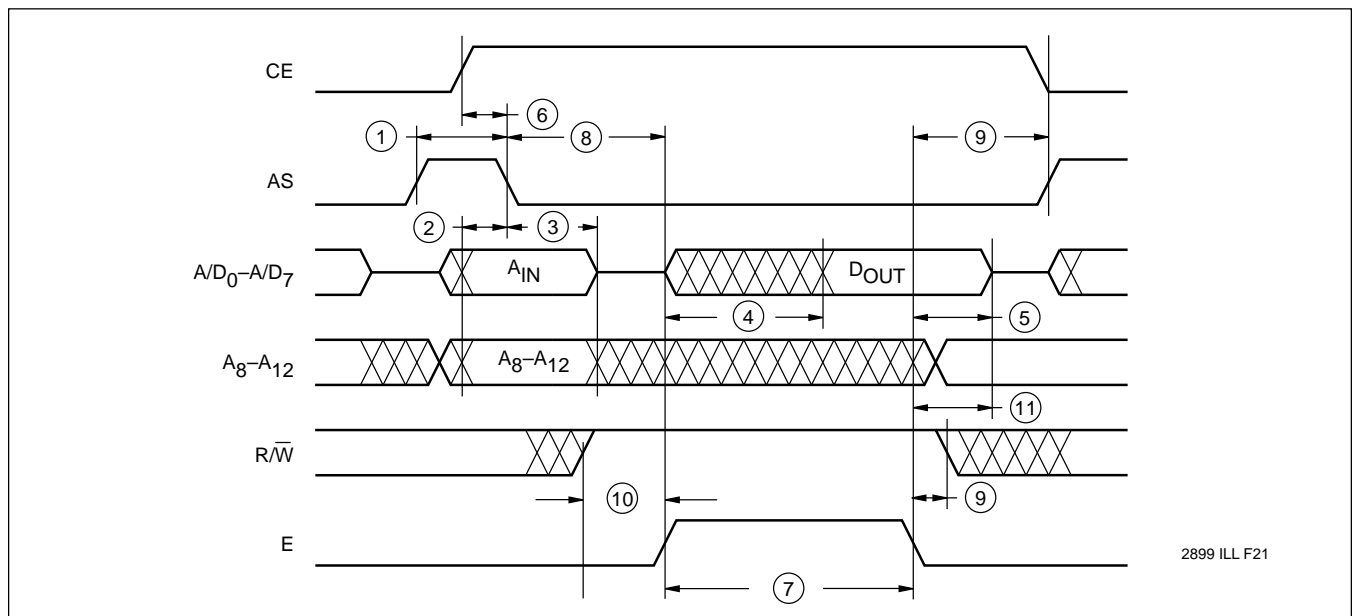
## A.C. CHARACTERISTICS (Over the recommended operating conditions unless otherwise specified.)

### E Controlled Read Cycle

No.	Symbol	Parameter	Min.	Max.	Units
1	PW <sub>ASH</sub>	Address Strobe Pulse Width	80		ns
2	t <sub>ASL</sub>	Address Setup Time	20		ns
3	t <sub>AHL</sub>	Address Hold Time	30		ns
4	t <sub>ACC</sub>	Data Access Time		120	ns
5	t <sub>DHR</sub>	Data Hold Time	0		ns
6	t <sub>CSL</sub>	CE Setup Time	7		ns
7	PW <sub>EH</sub>	E Pulse Width	150		ns
8	t <sub>ES</sub>	Enable Setup Time	30		ns
9	t <sub>EH</sub>	E Hold Time	20		ns
10	t <sub>RWS</sub>	R/ $\bar{W}$ Setup Time	20		ns
11	t <sub>HZ</sub> <sup>(5)</sup>	E LOW to High Z Output		50	ns

2899 PGM T10.1

### E Controlled Read Cycle



**Note:** (5) This parameter is periodically sampled and not 100% tested.

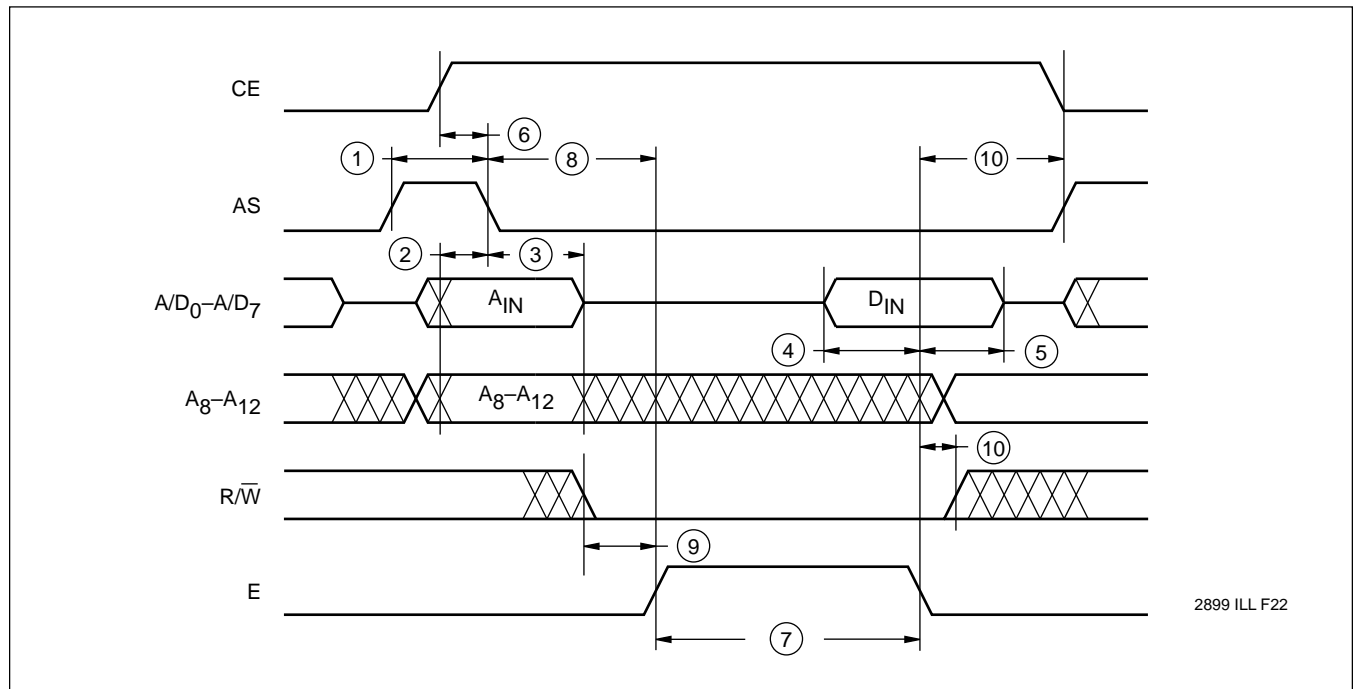
# X68C75 SLIC® E<sup>2</sup>

## E Controlled Write Cycle

No.	Symbol	Parameter	Min.	Max.	Units
1	PW <sub>ASH</sub>	Address Strobe Pulse Width	80		ns
2	t <sub>ASL</sub>	Address Setup Time	20		ns
3	t <sub>AHL</sub>	Address Hold Time	30		ns
4	t <sub>DSW</sub>	Data Setup Time	50		ns
5	t <sub>DHW</sub>	Data Hold Time	30		ns
6	t <sub>CSL</sub>	CE Setup Time	7		ns
7	PW <sub>EH</sub>	E Pulse Width	120		ns
8	t <sub>ES</sub>	Enable Setup Time	30		ns
9	t <sub>RWS</sub>	R/ $\bar{W}$ Setup Time	20		ns
10	t <sub>EH</sub>	E Hold Time	20		ns
11	t <sub>WC</sub>	Write Cycle Time		5	ms
12	t <sub>BLC</sub>	Byte Load Time (Page Write)	0.5	100	$\mu$ s

2899 PGM T11

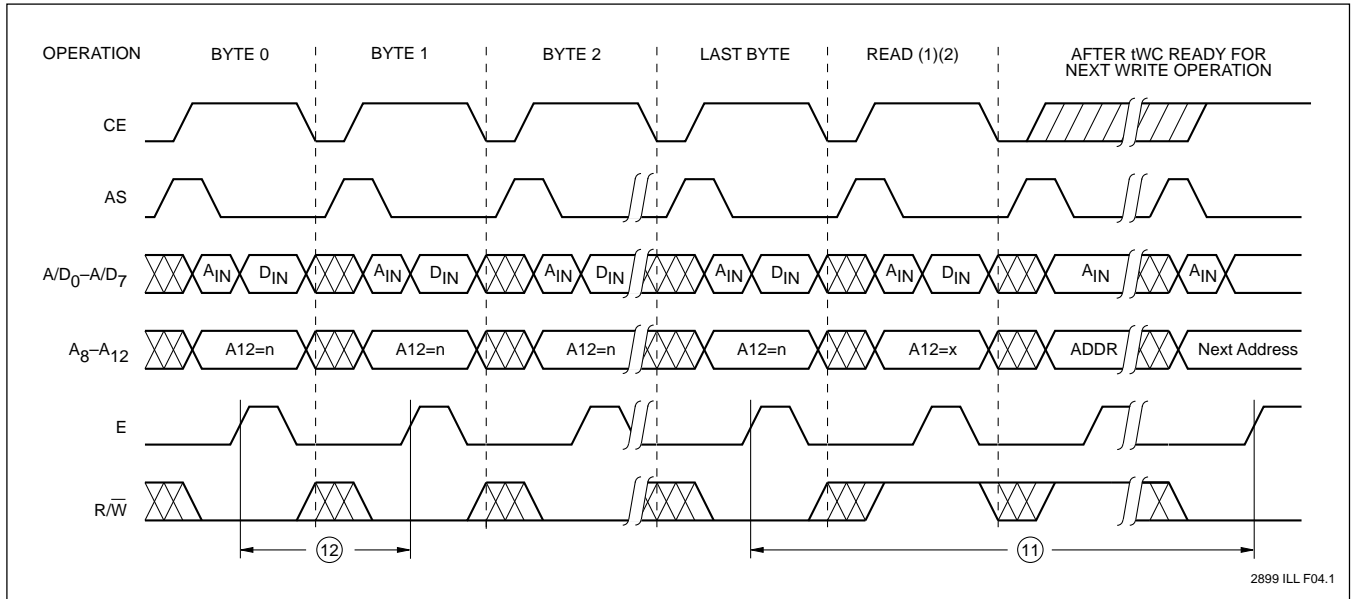
## E Controlled Write Cycle



2899 ILL F22

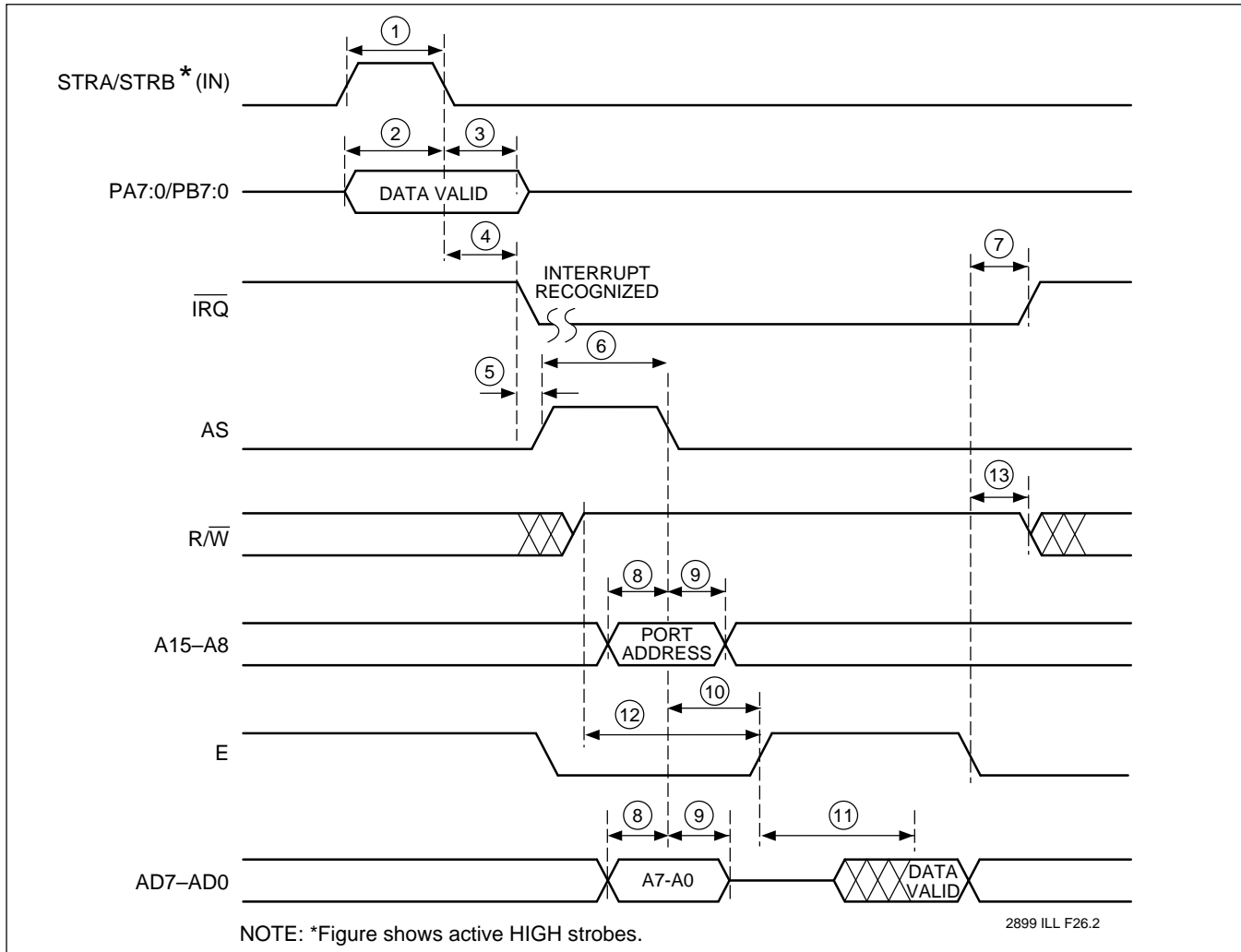
# X68C75 SLIC® E<sup>2</sup>

## Page Write Timing Sequence for E Controlled Operation



# X68C75 SLIC® E<sup>2</sup>

## Port Read Diagram



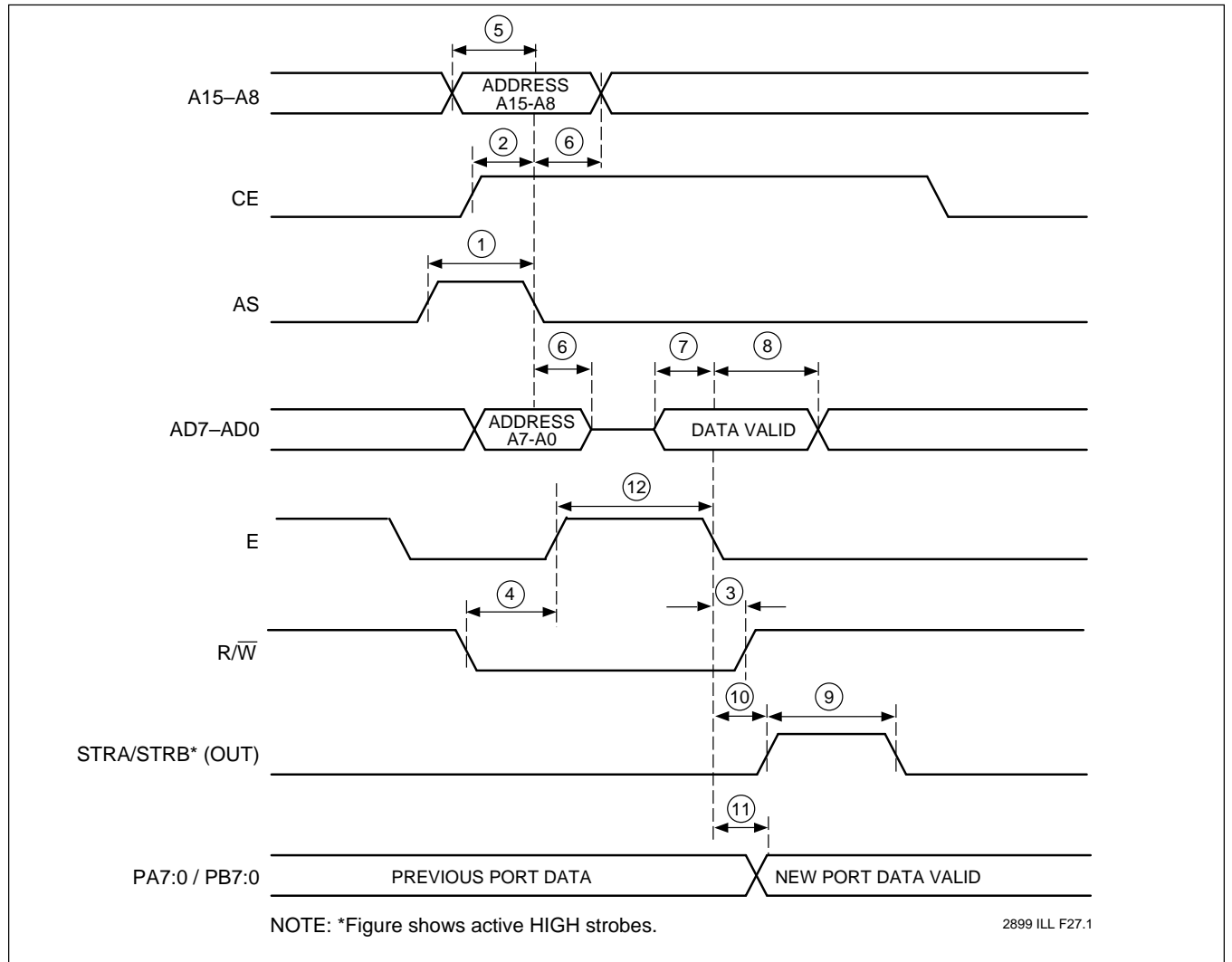
## PORT READ TIMING

No.	Symbol	Parameter	Min.	Max.	Units
1	$t_{SVSX}$	Strobe Pulse Width	80		ns
2	$t_{tS}$	Data Port Setup	20		ns
3	$t_{tH}$	Data Port Hold Time	30		ns
4	$t_{SVIV}$	Interrupt Request to Strobe		50	ns
5	$t_{tAD}$	$\overline{IRQ}$ to AS	0		ns
6	$PW_{ASH}$	AS Pulse Width	80		ns
7	$t_{RXIX}$	E to $\overline{IRQ}$ High	30		ns
8	$t_{ASL}$	Address setup time	20		ns
9	$t_{AHL}$	Address hold time	30		ns
10	$t_{ASE}$	AS to E High	30		ns
11	$t_{ACCE}$	E Access Time		120	ns
12	$t_{RWS}$	$\overline{R/W}$ Setup Time	30		ns
13	$t_{RWH}$	$\overline{R/W}$ Hold time	10		ns

2899 PGM T12.1

# X68C75 SLIC® E<sup>2</sup>

## Port Write Diagram



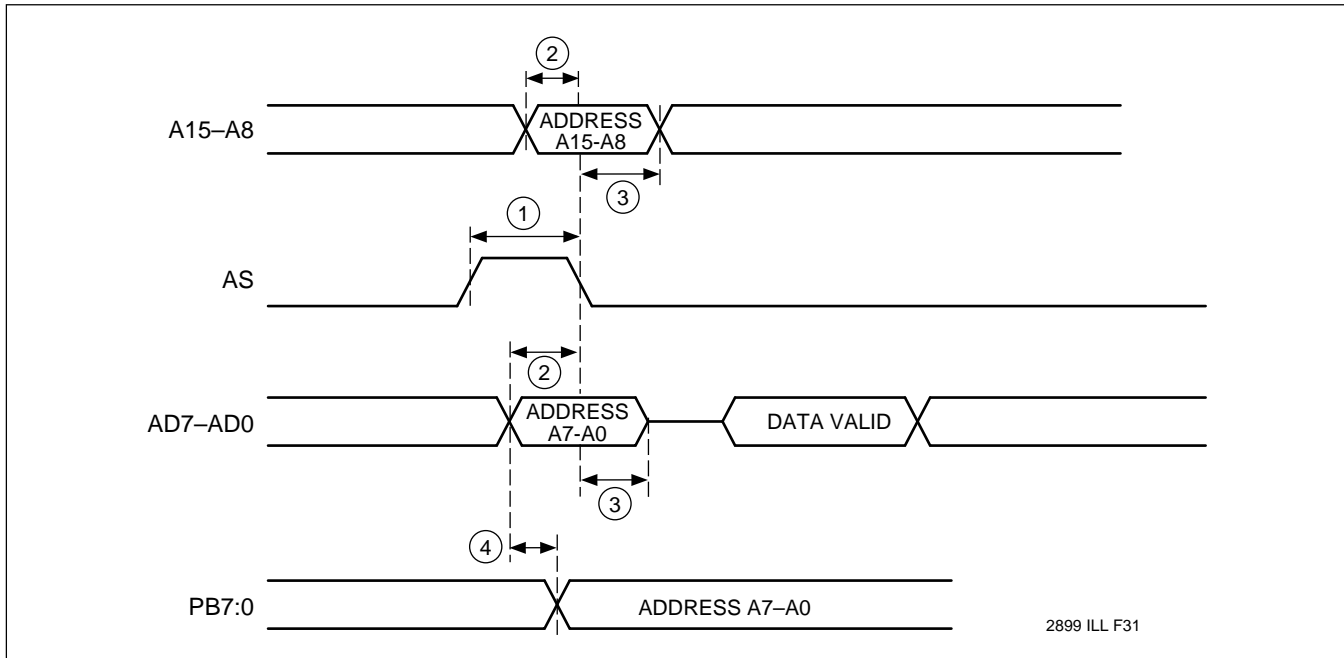
## PORT WRITE TIMING

No.	Symbol	Parameter	Min.	Max.	Units
1	PWASH	AS Pulse Width	80		ns
2	t <sub>WCS</sub>	Write Chip Select Setup Time	20		ns
3	t <sub>WH</sub>	Write Pulse Hold Time	10		ns
4	t <sub>WV</sub>	Write Pulse Valid to E Rise	30		ns
5	t <sub>AVLL</sub>	Address Setup Time	20		ns
6	t <sub>LLAX</sub>	Write Address Hold Time	30		ns
7	t <sub>DVWH</sub>	Data Setup Time	50		ns
8	t <sub>WHDX</sub>	Data Hold Time	10		ns
9	t <sub>SVSX</sub>	Strobe Pulse Width	120		ns
10	t <sub>QVSV</sub>	Strobe Access Time		40	ns
11	t <sub>POS</sub>	Port Output Setup Time		40	ns
12	PWEH	E Clock Pulse Width	150		ns

2899 PGM T13.1

# X68C75 SLIC® E<sup>2</sup>

## LAM (Latch Address Mode) Diagram



## LAM TIMING

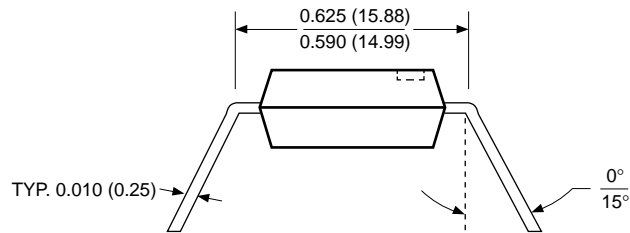
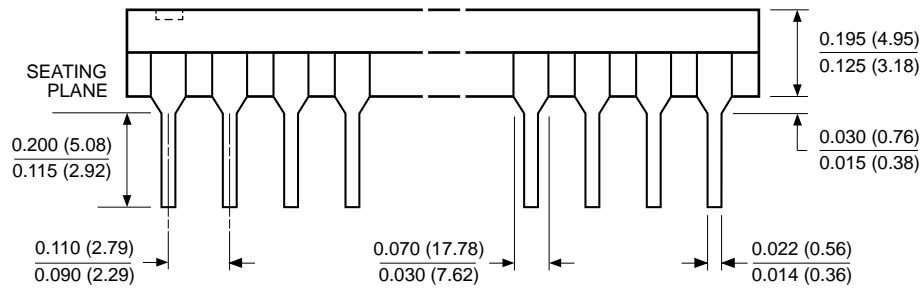
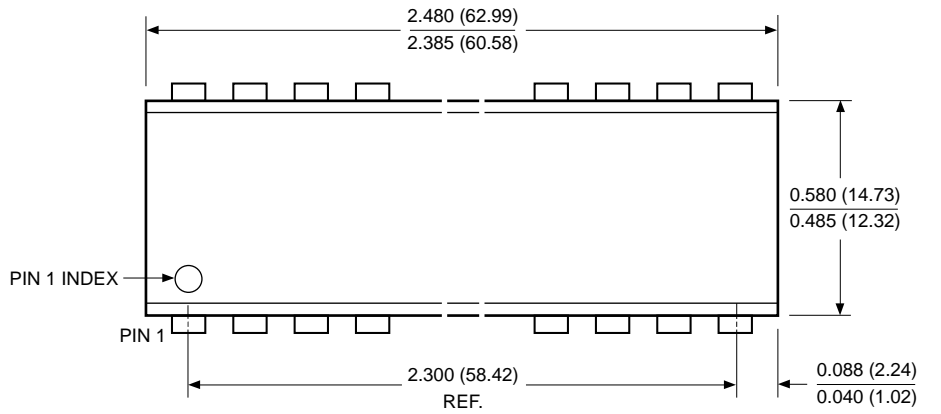
No.	Symbol	Parameter	Min.	Max.	Units
1	t <sub>LHLL</sub>	AS Pulse Width	80		ns
2	t <sub>AVLL</sub>	Address Setup Time	20		ns
3	t <sub>LLAX</sub>	Address Hold Time	30		ns
4	t <sub>POS</sub>	Port Output Setup Time		20	ns

2899 PGM T14.1

# X68C75 SLIC® E<sup>2</sup>

## PACKAGING INFORMATION

### 48-LEAD PLASTIC DUAL IN-LINE PACKAGE TYPE P



#### NOTE:

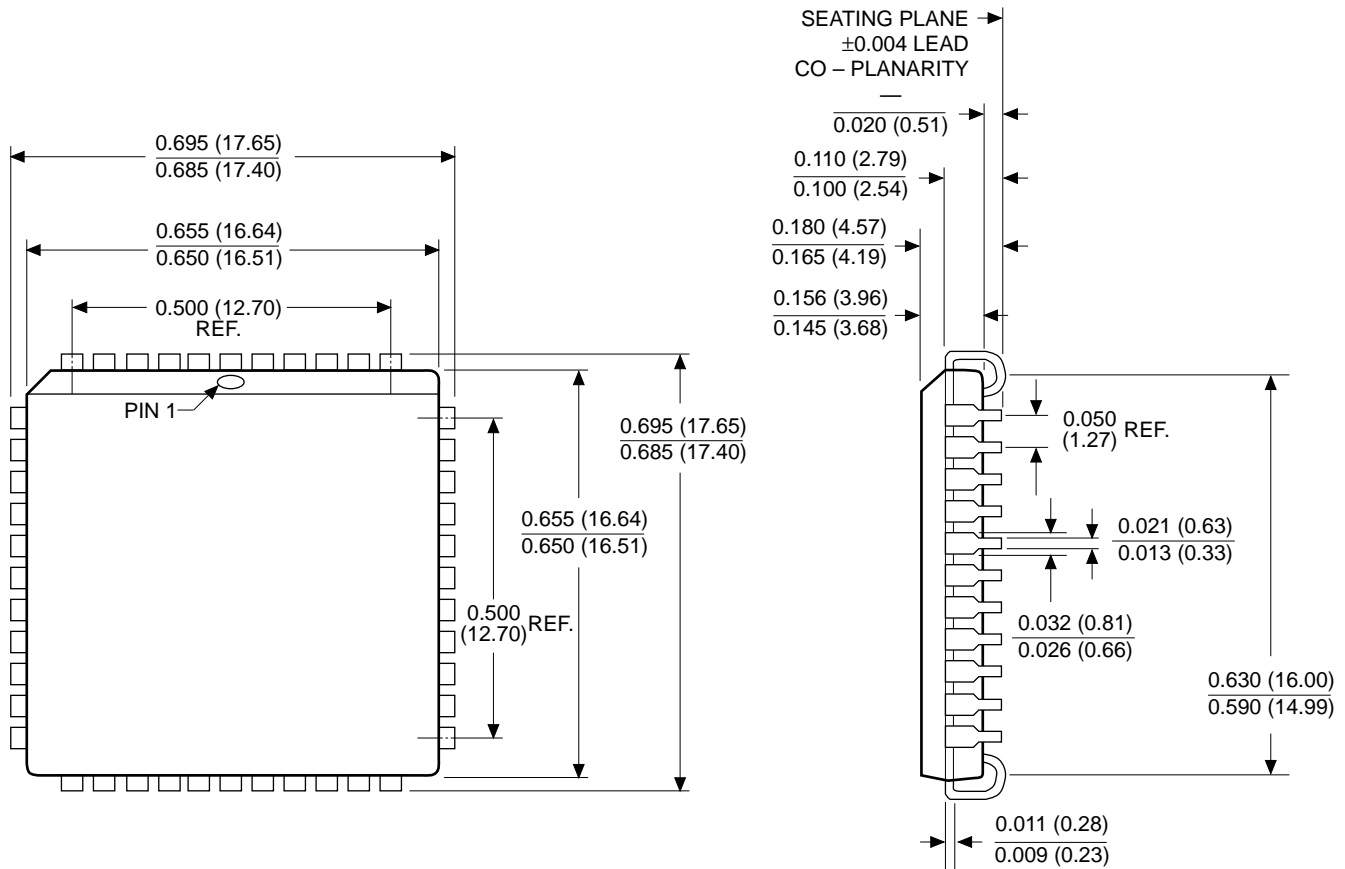
1. ALL DIMENSIONS IN INCHES (IN PARENTHESES IN MILLIMETERS)
2. PACKAGE DIMENSIONS EXCLUDE MOLDING FLASH

3926 FHD F43.1

# X68C75 SLIC® E<sup>2</sup>

## PACKAGING INFORMATION

### 44-PIN PLASTIC LEADED CHIP CARRIER PACKAGE TYPE J



**NOTES:**

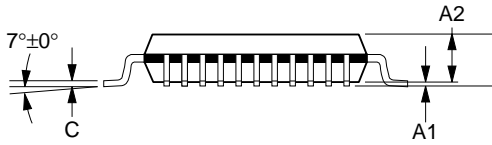
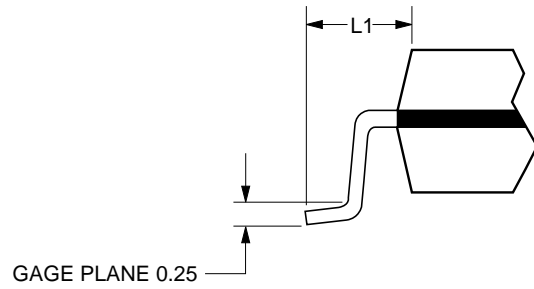
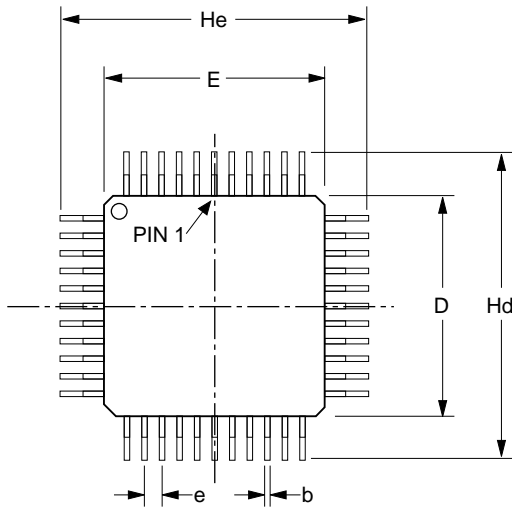
1. ALL DIMENSIONS IN INCHES (IN PARENTHESES IN MILLIMETERS)
2. DIMENSIONS WITH NO TOLERANCE FOR REFERENCE ONLY

3926 ILL F29.2

# X68C75 SLIC® E<sup>2</sup>

## PACKAGING INFORMATION

### 44-LEAD THIN QUAD FLAT PACK (TQFP) PACKAGE TYPE L



DIM	MILLIMETERS		INCHES	
	MIN	MAX	MIN	MAX
A <sub>1</sub>	0.05	0.15	0.002	0.006
A <sub>2</sub>	1.35	1.45	0.053	0.057
b	0.22	0.38	0.009	0.015
c	0.090	0.200	0.004	0.008
D	9.90	10.10	0.390	0.398
E	9.90	10.10	0.390	0.398
e	0.80 TYP		0.031 TYP	
Hd	11.90	12.10	0.468	0.476
He	11.90	12.10	0.468	0.476
L <sub>1</sub>	1.00 TYP		0.039 TYP	

**NOTES:**

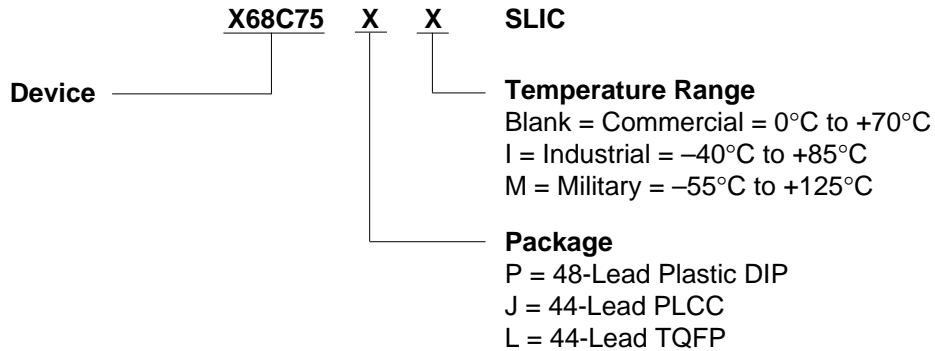
1. GAGE PLANE DIMENSION IS IN MM.
2. LEAD COPLANARITY SHALL BE 0.10MM [0.004] MAXIMUM.

3926 ILL F36.4

# X68C75 SLIC® E<sup>2</sup>

---

## ORDERING INFORMATION



---

### LIMITED WARRANTY

Devices sold by Xicor, Inc. are covered by the warranty and patent indemnification provisions appearing in its Terms of Sale only. Xicor, Inc. makes no warranty, express, statutory, implied, or by description regarding the information set forth herein or regarding the freedom of the described devices from patent infringement. Xicor, Inc. makes no warranty of merchantability or fitness for any purpose. Xicor, Inc. reserves the right to discontinue production and change specifications and prices at any time and without notice.

Xicor, Inc. assumes no responsibility for the use of any circuitry other than circuitry embodied in a Xicor, Inc. product. No other circuits, patents, licenses are implied.

### US. PATENTS

Xicor products are covered by one or more of the following U.S. Patents: 4,263,664; 4,274,012; 4,300,212; 4,314,265; 4,326,134; 4,393,481; 4,404,475; 4,450,402; 4,486,769; 4,488,060; 4,520,461; 4,533,846; 4,599,706; 4,617,652; 4,668,932; 4,752,912; 4,829,482; 4,874,967; 4,883,976; 4,980,859; 5,012,132; 5,003,197; 5,023,694. Foreign patents and additional patents pending.

### LIFE RELATED POLICY

In situations where semiconductor component failure may endanger life, system designers using this product should design the system with appropriate error detection and correction, redundancy and back-up features to prevent such an occurrence.

Xicor's products are not authorized for use as critical components in life support devices or systems.

1. Life support devices or systems are devices or systems which, (a) are intended for surgical implant into the body, or (b) support or sustain life, and whose failure to perform, when properly used in accordance with instructions for use provided in the labeling, can be reasonably expected to result in a significant injury to the user.
2. A critical component is any component of a life support device or system whose failure to perform can be reasonably expected to cause the failure of the life support device or system, or to affect its safety or effectiveness.

**NOTES**

# X68C75 SLIC® E<sup>2</sup>

---

## U.S. SALES OFFICES

### Corporate Office

Xicor Inc.  
1511 Buckeye Drive  
Milpitas, CA 95035  
Phone: 408/432-8888  
Fax: 408/432-0640  
E-mail: info@smtpgate.xicor.com

### Northeast Region

Xicor Inc.  
1344 Main Street  
Waltham, MA 02154  
Phone: 617/899-5510  
Fax: 617/899-6808  
E-mail: xicor-ne@smtpgate.xicor.com

### Southeast Region

Xicor Inc.  
100 E. Sybelia Ave.  
Suite 355  
Maitland, FL 32751  
Phone: 407/740-8282  
Fax: 407/740-8602  
E-mail: xicor-se@smtpgate.xicor.com

### Mid-Atlantic Region

Xicor Inc.  
50 North Street  
Danbury, CT 06810  
Phone: 203/743-1701  
Fax: 203/794-9501  
E-mail: xicor-ma@smtpgate.xicor.com

### North Central Region

Xicor Inc.  
810 South Bartlett Road  
Suite 103  
Streamwood, IL 60107  
Phone: 708/372-3200  
Fax: 708/372-3210  
E-mail: xicor-nc@smtpgate.xicor.com

### South Central Region

Xicor Inc.  
11884 Greenville Ave.  
Suite 102  
Dallas, TX 75243  
Phone: 214/669-2022  
Fax: 214/644-5835  
E-mail: xicor-sc@smtpgate.xicor.com

### Southwest Region

Xicor Inc.  
4100 Newport Place Drive  
Suite 710  
Newport Beach, CA 92660  
Phone: 714/752-8700  
Fax: 714/752-8634  
E-mail: xicor-sw@smtpgate.xicor.com

### Northwest Region

Xicor Inc.  
2700 Augustine Drive  
Suite 219  
Santa Clara, CA 95054  
Phone: 408/292-2011  
Fax: 408/980-9478  
E-mail: xicor-nw@smtpgate.xicor.com

---

## INTERNATIONAL SALES OFFICES

### EUROPE

#### Northern Europe

Xicor Ltd.  
Grant Thornton House  
Witan Way  
Witney  
Oxford OX8 6FE  
UK  
Phone: (44) 1933.700544  
Fax: (44) 1933.700533  
E-mail: xicor-uk@smtpgate.xicor.com

#### Central Europe

Xicor GmbH  
Technopark Neukeferloh  
Bretonischer Ring 15  
85630 Grasbrunn bei Muenchen  
Germany  
Phone: (49) 8946.10080  
Fax: (49) 8946.05472  
E-mail: xicor-gm@smtpgate.xicor.com

### ASIA/PACIFIC

#### Japan

Xicor Japan K.K.  
Suzuki Building, 4th Floor  
1-6-8 Shinjuku, Shinjuku-ku  
Tokyo 160, Japan  
Phone: (81) 3322.52004  
Fax: (81) 3322.52319  
E-mail: xicor-jp@smtpgate.xicor.com

#### Mainland China

#### Taiwan/Hong Kong

Xicor Inc.  
4100 Newport Place Drive  
Suite 710  
Newport Beach, CA 92660  
Phone: 714/752-8700  
Fax: 714/752-8634  
E-mail: xicor-sw@smtpgate.xicor.com

### Singapore/Malaysia/India

Xicor Inc.  
2700 Augustine Drive  
Suite 219  
Santa Clara, CA 95054  
Phone: 408/292-2011  
Fax: 408/980-9478  
E-mail: xicor-nw@smtpgate.xicor.com

### Korea

Xicor Korea  
27th Fl., Korea World Trade Ctr.  
159, Samsung-dong  
Kangnam Ku  
Seoul 135-729  
Korea  
Phone: (82) 2551.2750  
Fax: (82) 2551.2710  
E-mail: xicor-ka@smtpgate.xicor.com

( ) = Country Code

**Xicor product information is available at:**

**<http://www.xicor.com>**